

DESIGN AND ANALYSIS OF OTA WITH SAPON CIRCUIT USING CMOS TECHNOLOGY

¹Chetan Shankarappa Mundinamani, ²Meghana Kulkarni, ³Aishwarya Payannavar

¹PG Scholar, ²Associate Professor, ³Assistant Professor

¹Electronics and communication Engineering,

¹Visvesvaraya Technological University, Belagavi, Karnataka, India

Abstract : This represents a low-power OTA enhanced with a SAPON (Self-Adaptive Power Optimization Network) technique, to achieving low power and energy efficiency for Low power applications. In modern electronic systems, especially wearable and implantable devices, reducing power consumption while maintaining reliable performance is a critical challenge due to limited battery capacity and the need for continuous operation. Overall, the proposed SAPON-based OTA successfully achieves the average power consumption is obtained using the Cadence Virtuoso calculator by evaluating the power waveform generated during transient simulation. The calculated average power consumption of the proposed OTA is **3.25 μ W**, which is lower than that of the existing OTA. The proposed OTA achieves approximately **25.12%** lower power consumption compared to the existing OTA, confirming the effectiveness of the SAPON-based power optimization technique.

IndexTerms – OTA, Low-power, SAPON, Power consumption, low-voltage, energy efficiency

I. INTRODUCTION

An Operational Transconductance Amplifier (OTA) is a voltage-controlled current source widely used in analog integrated circuit design. Extensively utilized in the design of analog integrated circuits. An OTA converts the differential input in contrast to traditional operational amplifiers that generate a voltage output. voltage into a current at the output. A parameter called determines the proportionality between the input voltage and output current. transconductance (gm) which is controlled electronically by a bias current. In this context OTA have become a widely preferred solution due to their inherent advantages such as high. tunability a straightforward design and outstanding CMOS technology compatibility. These OTAs make it simple to control important parameters like gain and cutoff frequency by adjusting the bias current. making them extremely versatile for a variety of biomedical uses.

Conventional OTA-based designs on the other hand are typically tailored for more extensive analog applications. In order to achieve adequate performance, they usually require higher bias currents and operate at higher supply voltages. transconductance and bandwidth leading to higher power usage. For battery-powered gadgets like wearables and implantable systems this is a significant disadvantage. Device lifetime and usability are directly impacted by efficiency. Furthermore, complex architectures like multiple gain and cascoding are frequently used in conventional OTA circuits. stages which expand the silicon area by increasing the number of transistors. Because of this they are less appropriate for small space-constrained healthcare devices. Maintaining important performance metrics like linearity noise efficiency and so forth is another significant challenge. dynamic range when reducing the voltage of the supply. Signal distortion and degradation result from reduced voltage headroom which restricts transistor's ability to function properly. demonstration. Furthermore low-frequency biosignal processing is more susceptible to flicker noise. prevalent in CMOS devices and has a substantial impact on signal accuracy. Conventional reliable operation is further complicated by variations in process voltage and temperature (PVT). Adaptive mechanisms to account for these shifts are frequently absent from designs. Optimized low-voltage OTA designs that can get around these restrictions are therefore obviously needed. reducing power consumption and maintaining high performance ultimately enabling efficient and biomedical. systems performance and ultimately making low power applications dependable and effective.

II. RELATED WORK

A comprehensive review of recent research on Operational Transconductance Amplifiers (OTAs) for biomedical applications reveals that significant efforts have been made to improve power efficiency, noise performance, gain, and area utilization. EEG and EMG are examples of physiological signals that make these parameters crucial in biomedical systems. have extremely low amplitudes and need precise low-power amplification.[1]

The suggested method effectively decreased silicon area and power consumption without compromising suitability. for biomedical signals with low frequencies. The design proved how low-voltage operation can effectively produce an energy-efficient signal. manipulation. However, there are restrictions on gain signal swing and low-voltage performance trade-offs. were determined. It is clear from the reviewed literature that there has been significant advancement in OTA designs. Nevertheless, there are still difficulties in creating an OTA architecture that can provide ultra at the same time.[2]

low noise high gain sufficient bandwidth small size reliable operation and low power consumption. different circumstances. However, challenges remain in developing a single OTA architecture capable of simultaneously providing ultra-low power

consumption, low noise, high gain, adequate bandwidth, and robust operation under varying conditions. These limitations motivate further research toward designing an optimized OTA structure that balances all critical performance parameters for next-generation biomedical systems.[3]

III.METHODOLOGY

3.1 PROPOSED METHOD

The SAPON (Self-Adaptive Power Optimization Network) technique is an advanced power management approach aimed at significantly reducing energy consumption in analog and mixed-signal circuits, particularly in low-power VLSI designs. Unnecessary power dissipation occurs especially during idle or low-activity periods because conventional circuits maintain a fixed bias current regardless of the input signal conditions. In contrast SAPON incorporates an adaptive mechanism that continuously monitors the input signal activity while dynamically altering the circuits biasing conditions. The circuit reduces the current when the signal activity is low and only increases it when the signal requires higher performance (e. g. during abrupt signal changes) in order to conserve energy.

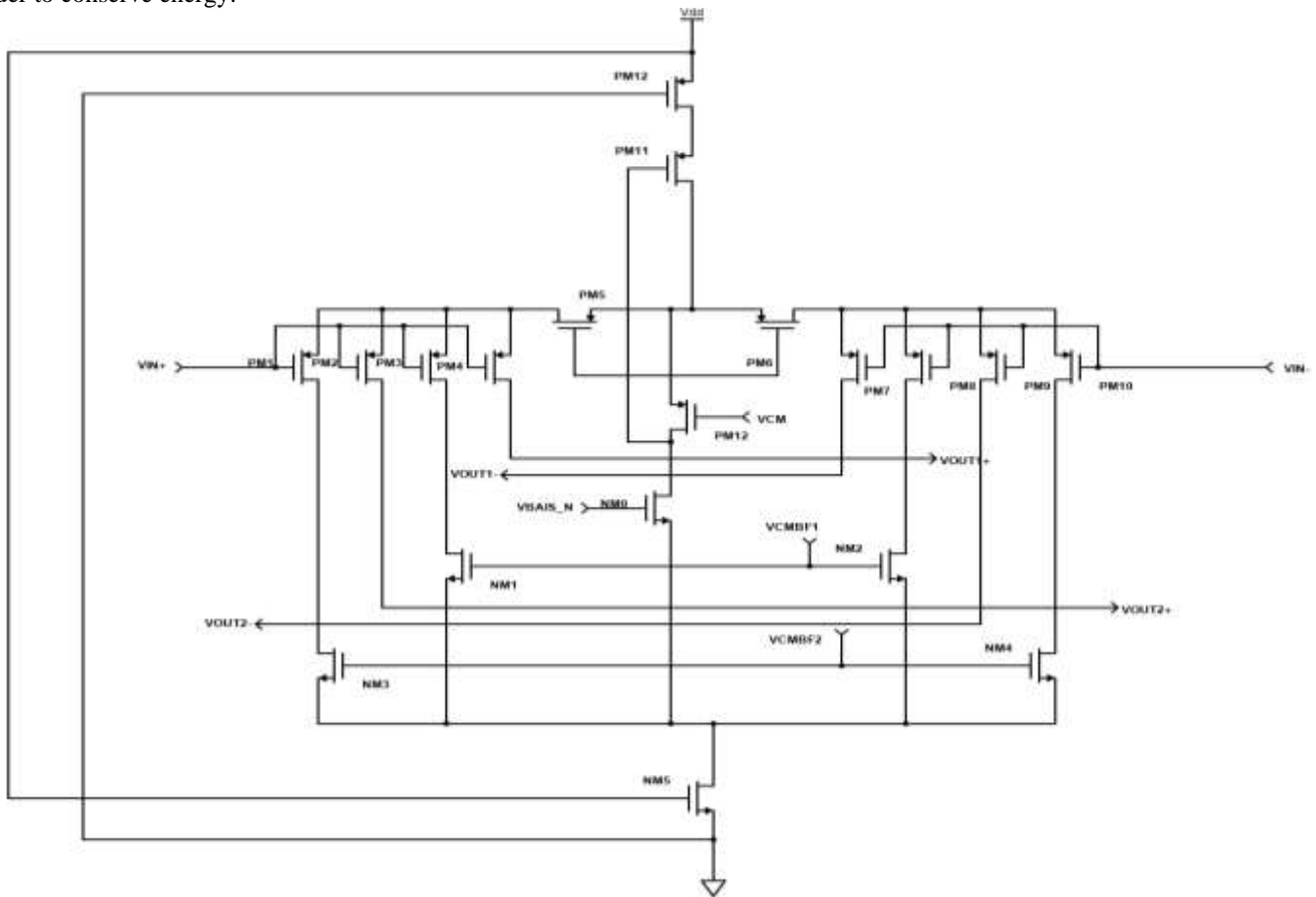

Fig 1: Proposed SAPON OTA

SAPON is an intelligent power optimization methodology that dynamically adjusts the biasing conditions of a circuit according to its instantaneous performance requirements. The method continuously monitors circuit activity rather than running at a fixed power level. automatically controls the bias current. SAPON lowers the current to minimize power when the circuit is operating in low-demand conditions utilization.

On the other hand, in order to maintain the desired gain, the bias current is increased when higher performance is needed. quality of the signal and bandwidth. While maintaining circuit functionality this adaptive operation allows for the effective use of power resources. Enhancing battery life and lowering heat is another significant benefit of the SAPON technique, generation.

Low-voltage operation which is becoming more and more crucial in contemporary CMOS is also supported by the SAPON technique. technologies. The method makes it possible for circuits to operate evenly by cleverly regulating current flow. at lower voltages of the supply. This leads to increased energy efficiency and makes it possible to create affordable portable and small devices, electrical systems.

Energy waste occurs when the circuit only uses the power needed for a specific operation reduced. This feature is especially helpful for biomedical devices that require low power and long-term operation. consumption are essential prerequisites. Reduced power dissipation also helps to increase dependability and lessen thermal stress. combined circuit

The Figure 2 shows the circuit of Self-Adaptive Power Optimization Network (SAPON), which is designed to reduce power consumption while maintaining the required circuit performance.

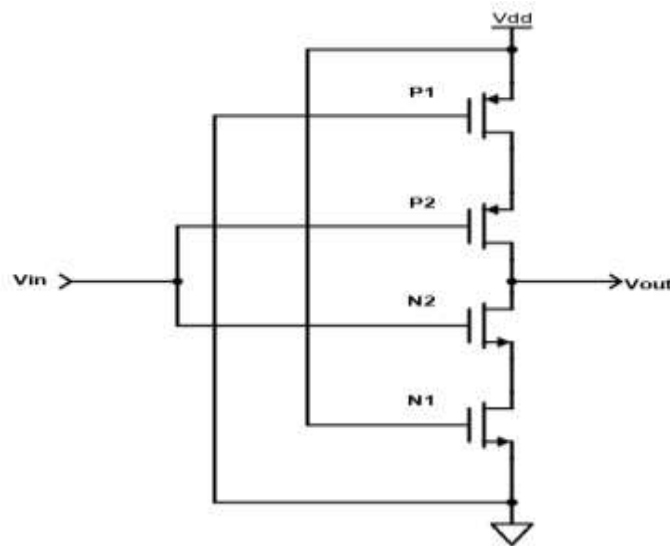

Fig 2: SAPON Technique

The SAPON technique operates by dynamically controlling the bias current of the circuit according to its instantaneous operating requirements. Unlike conventional circuits that use a fixed bias current and continuously consume power SAPON intelligently maintains the necessary performance while lowering needless energy consumption by adjusting the current level.

IV. CIRCUIT DESIGN

The key feature of the proposed OTA is the integration of the SAPON-based adaptive biasing network. Unlike conventional fixed-bias circuits, the SAPON technique dynamically regulates the bias current according to the operating conditions of the circuit. During low-activity conditions, the bias current is reduced to minimize power dissipation, whereas sufficient current is supplied during higher activity levels to maintain proper amplification performance. This adaptive operation significantly improves energy efficiency without compromising signal quality.

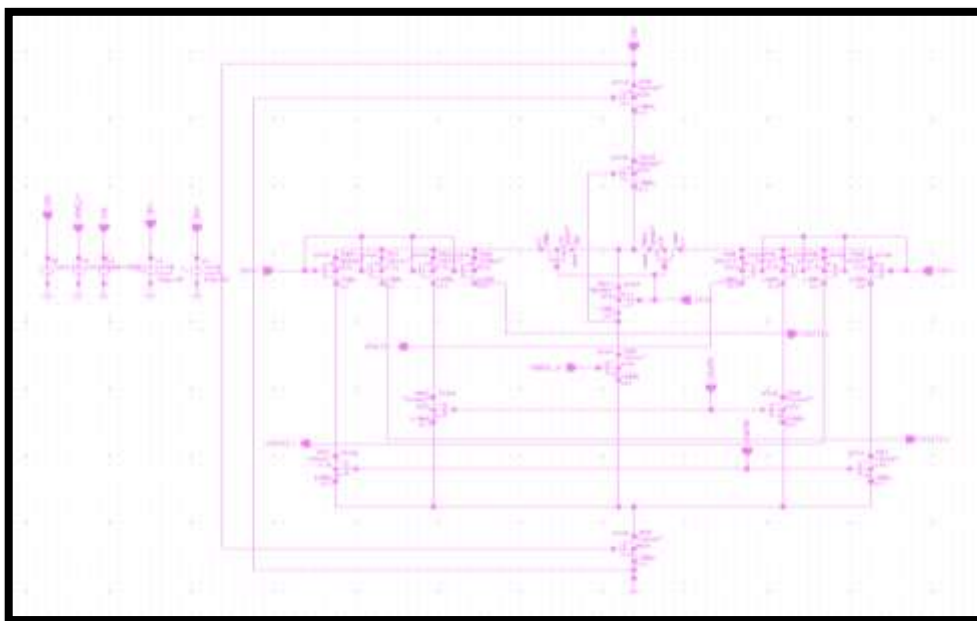

Fig 3: Schematic of Proposed OTA

Fig 3 illustrates the transistor-level schematic of the proposed Operational Transconductance Amplifier (OTA) implemented in Cadence Virtuoso using 45 nm CMOS technology. The proposed design incorporates a Self-Adaptive Power Optimization 18 Network (SAPON) to achieve reduced power consumption while maintaining the required gain, transconductance, and stability. The architecture consists of a differential input stage, adaptive biasing network, current steering transistors, common-mode feedback circuitry, and output amplification stages.

The transistors forming the common-mode feedback (CMFB) network continuously monitor the output common-mode voltage through the nodes VCM, VCMBF1, and VCMBF2. The feedback mechanism automatically adjusts the biasing conditions to stabilize the output voltage level and maintain balanced differential operation. This improves linearity, output stability, and overall

reliability of the amplifier. The NMOS tail current transistor regulates the overall current flowing through the OTA and works together with the SAPON network to optimize power consumption.

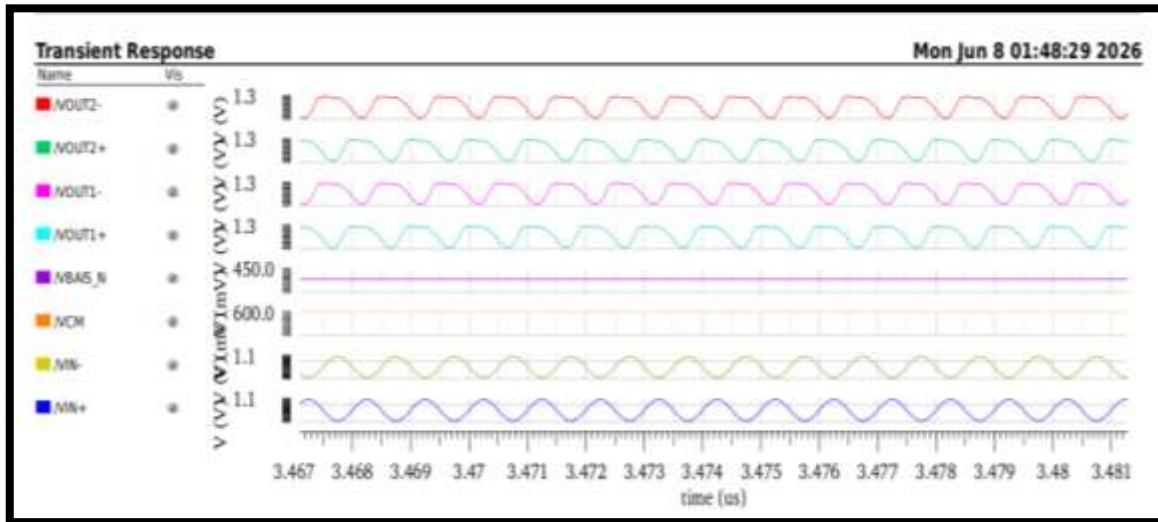

Fig 4: Waveform of Proposed OTA

V. Layout Design and Physical Verification

The proposed OTA with SAPON Techniques physical layout was implemented using the Cadence Virtuoso Layout Editor following the successful verification of the schematic design through transient simulations. Layout design is one of the most important stages in the VLSI design process since it transforms the circuit schematic into a manufacturable physical representation. The layout determines the actual placement of transistors the routing of connections and the use of various fabrication layers required for integrated circuit fabrication. A well-designed layout ensures reliable circuit performance in addition to lowering delay and power consumption.

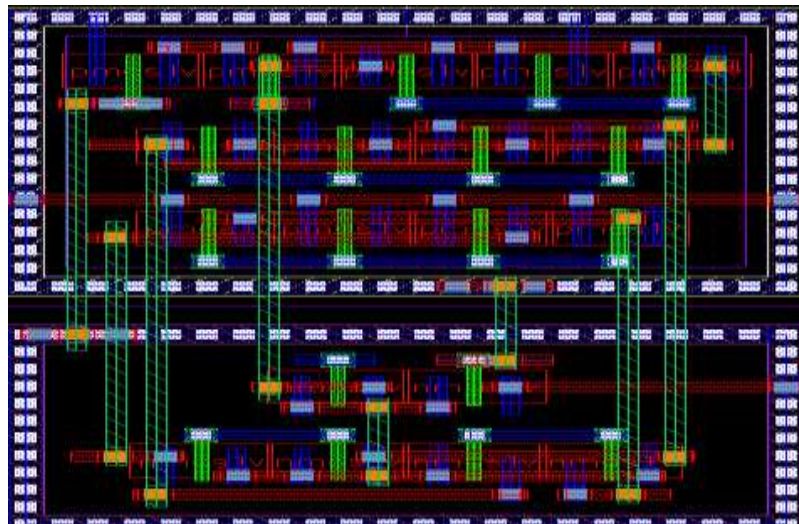

Fig 5: Layout design of Proposed OTA

The layout was optimized by reducing unnecessary routing lengths lowering overlap capacitances and maintaining the proper separation between signal lines. By following these procedures, the intended behaviour of the manufactured circuit is ensured and the performance gains made at the schematic level are maintained.

VI. RESULTS AND DISCUSSIONS

This chapter presents a comprehensive analysis of the Operational Transconductance Amplifier C-Filter, low power consumption and moscount values as shown Table 1. The comparison of Power values between the Existing OTA and the Sapon Based OTA reveals a significant improvement in energy efficiency. The Existing OTA records a power consumption of $4.342E-6$ watts, whereas the Sapon Based OTA achieves a reduced value of $3.252E-6$ watts, reflecting nearly a 25% decrease in power dissipation. This reduction is highly significant in analog integrated circuit design, as lower power consumption directly contributes to reduced heat generation, improved thermal stability, and extended battery life in portable applications.

To evaluate the effectiveness of the proposed OTA with the SAPON technique, its performance was compared with that of the existing OTA under identical simulation conditions using Cadence Virtuoso in using CMOS technology. Important performance parameters such as power consumption, transistor count, area and output stability were analyzed to assess the improvements achieved by the proposed design.

Table 1. Comparison of Existing OTA with SAPON Based OTA

Parameter	Existing OTA	SAPON Based OTA
Power	4.342E-6	3.252E-6
Moscount	17	19

The percentage reduction in power consumption is calculated as:

$$\text{Power Reduction (\%)} = \frac{4.34 - 3.25}{4.34} \times 100$$

$$\text{Power Reduction (\%)} = 25.12\%$$

Thus, the proposed OTA achieves approximately **25.12%** lower power consumption compared to the existing OTA, confirming the effectiveness of the SAPON-based power optimization approach.

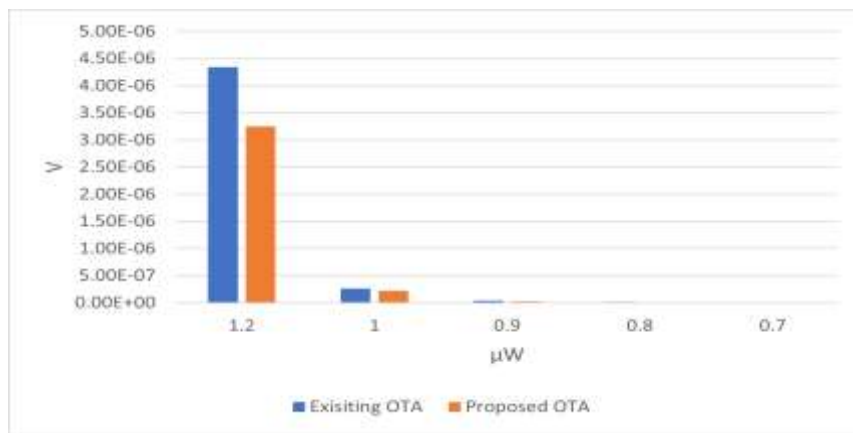

Fig 6: Graph representing Existing and proposed OTA Power and Voltage

The graph illustrates the variation of power consumption with respect to supply voltage for both the existing and proposed OTA designs. As the supply voltage increases, power consumption rises in both circuits. However, the proposed OTA consistently exhibits lower power consumption than the existing design due to the incorporation of the SAPON-based adaptive biasing technique. This demonstrates the effectiveness of the proposed architecture in achieving improved energy efficiency while maintaining the required circuit performance.

Additionally, the adaptive biasing mechanism and optimized transistor architecture increase the total energy. circuit efficiency without compromising its amplification capabilities. The suggested design offers a significant decrease in transistor count despite having a marginally higher number. power usage and improved dependability of operations. Because of these enhancements the suggested OTA is ideal for low-power OTA implementations. Energy-efficient VLSI applications include wearable medical equipment and biomedical signal processing systems.

VII.CONCLUSION AND FUTURE SCOPE

The suggested OTAs performance and functionality were assessed through transient simulations. The simulation results verified stable differential output generation and proper circuit operation. In contrast to the suggested OTA the average power consumption of the current OTA was found to be **4.34 μW**. only used **3.25 μW**. This illustrates the SAPONs efficacy with a power reduction of about **25.12 percent**. based on an adaptive biasing strategy. Furthermore, the suggested design preserved dependable signal enhanced energy efficiency and stable operation. amplification appropriate for analog applications with low power.

The optimized transistor-level architecture and SAPON technique contribute to reduced. power loss while maintaining the necessary output stability and gain. The suggested OTA uses a little more transistor but the energy efficiency is still improved. justifies the extra circuitry. Thus low-power biomedical signals are a good fit for the suggested OTA with SAPON technique. processing

biosignal acquisition systems wearable medical equipment and other VLSI with limited energy. utilities. The results obtained confirm the efficacy of the suggested design and show its future potential. low-power analogue integrated circuit designs.

Future work could include biosignal acquisition and integrating the OTA with full analog front-end circuits. systems and sophisticated platforms for health monitoring. Advanced CMOS or FinFET technologies are used for hardware fabrication and experimental validation of the design. can confirm its viability in practice. As a result, there is a good chance that the suggested architecture will be used in upcoming energy-efficient VLSI. systems and next-generation integrated circuits with low power consumption.

REFERENCES

- [1] J. B. Yogeshwar, Vikas Vijayvargiya, Alan Samuel, “Design and Analysis of Low Noise, Low Power OTA Considering Design Trade-Offs for Biomedical Applications” IEEE Conference on Biomedical Applications and Computing Technology 2025.
- [2] Mongkol Kumngern et al, “Analysis of a Low-Power OTA-Based Neural Amplifier Design for EEG Signal Acquisition”, 2024 International Conference on Circuit power and Cloud Computing.
- [3] M.Yip, R.Jinh. H. Nakajima. Stankovic, and A.P. Chandrakasan, “A fully-implantable cochlear implant SoC with piezoelectric middle-ear sensor and arbitrary waveform neural stimulation,” IEEE J. Solid-State Circuits, vol. 50, no. 1, pp. 214–229, Jan. 2015.
- [4] J. Bohorquez, M. Yip, A. Chandrakasan, and J. Dawson, “A biomedical sensor interface with a sinc filter and interference cancellation,” IEEE J. Solid-State Circuits, vol. 46, no. 4, pp. 746–756, Apr. 2011.
- [5] W.-M. Chen et al., “A fully integrated 8-channel closed-loop neural prosthetic CMOS SoC for real-time epileptic seizure control,” IEEE J. Solid-State Circuits, vol. 49, no. 1, pp. 232–247, Jan. 2014.
- [6] X. Zou, X. Xu, L. Yao, and Y. Lian, “A 1-V 450-nW fully integrated programmable biomedical sensor interface chip,” IEEE J. Solid-State Circuits, vol. 44, no. 4, pp. 1067–1077, Apr. 2009.
- [7] C. P. Wang, S. Y. Lee, and W. C. Lai, “An RFID tag system-on-chip with wireless ECG monitoring for intelligent healthcare systems,” in Proc. 35th Annu. Int. Conf. IEEE Eng. Med. Biol. Soc., Jul. 3–7, 2013, pp. 5489–5492.
- [8] C. C. Tu, F. W. Lee, and T. H. Lin, “An area-efficient capacitively coupled instrumentation amplifier with a duty-cycled Gm-C DC servo loop in 0.18,” in Proc. IEEE Asian Solid-State Circuits Conf., Nov. 2014, pp. 153–156.
- [9] P. Corbishley and E. Rodriguez-Villegas, “A nanowatt bandpass filter for detection of an acoustic signal in a wearable breathing detector,” IEEE Trans. Biomed. Circuits Syst., vol. 1, no. 3, pp. 163–171, Sep. 2007.
- [10] M. Yang, J. Liu, Y. Xiao, and H. Liao, “14.4 nW fourth-order band pass filter for biomedical applications,” Electron. Lett., vol. 46, no. 14, pp. 973–974, Jul. 2010.
- [11] Y.-P. Chen et al., “An injectable 64 nW ECG mixed-signal SoC in 65 nm for arrhythmia monitoring,” IEEE J. Solid-State Circuits, vol. 50, no. 1, pp. 375–390, Jan. 2015.
- [12] K. Salimi, F. Krummenachera, C. Dehollain, and M. Declercq, “Continuous-time CMOS circuits based on multi-tanh linearization principle,” Electron. Lett., vol. 38, no. 3, pp. 103–104, Jan. 2002. [16] I. Kianpour, B. Hussain, V. G. Tavares, and H. S. Mendonca, “A low-power multi-tanh OTA with very low harmonic distortion,” in Proc. IEEE Int. Symp. Circuits Syst., May 2015, pp. 645–649

Copyright & License:



© Authors retain the copyright of this article. This work is published under the Creative Commons Attribution 4.0 International License (CC BY 4.0), permitting unrestricted use, distribution, and reproduction in any medium, provided the original work is properly cited.