

Topology Optimization of Spur Gear

¹Sunkara Udaya Keerthi, ²R. Iswarya, ³CH. Hema Sridevi, ⁴V. Neha, ⁵Shaheen

¹Assistant Professor, ^{2,3,4,5}Final year under graduate student,

¹ Department of Mechanical Engineering,

¹ Andhra University College of Engineering for Women,
Visakhapatnam, India

Abstract : This study presents the analysis and topology optimization of a spur gear to achieve material reduction while maintaining structural performance. Initially, gear analysis is carried out to evaluate deformation under given loading conditions. Different optimized designs such as hybrid hole, radial spoke and circular perforated structures were analysed and compared. The best design was selected by comparing minimum deformation with the original gear. The results show that weight can be reduced without affecting strength, making the gear more efficient and suitable for practical applications.

1.INTRODUCTION

Spur gear is one of the most basic and common mechanical components used for transferring power between parallel shafts. The geometry of a spur gear consists of straight teeth arranged on a cylindrical surface. Because of the relatively simple geometry of the gear teeth, high torque and power can be transmitted through spur gears with comparatively little processing effort. Due to the simple geometry and the high strength of the gear teeth, spur gears find extensive applications in automotive transmissions, industrial components, gearboxes and mechanical drive systems, where simple, low-cost, high-strength mechanical systems are valuable. Although numerous spur gear designs have been presented in the literature, they commonly use a lot of material in non-critical regions, e.g., at the hub. The added material results in higher material costs and higher weight. Consequently, reducing the material in the spur gear and reducing the mass of the spur gear could be highly desirable in applications where lower mass will improve performance, e.g., in automotive applications.

Topology optimization is a novel computational design approach to remove material from a base structure while maintaining its mechanical performance above a pre-defined threshold. The advantage of the optimization lies in that it can be used to remove excess material from regions where material plays a minor role in carrying loads. The present work focuses upon the design of a spur gear undergoing loading. The design process aims at the removal of material from the hub region of the gear, which is considered as a region of excess material. The objective is to reduce the weight of the gear without compromising its performance. The gear is loaded at the rim, and the deformation and stress fields are analyzed following initial loading. Topology optimization is then applied to remove material from the hub region. The effect of design optimization on the load bearing capability and the deformation is analyzed. The benefits of adopting a topology optimized design are discussed, which include reduced manufacturing cost, increased energy efficiency, and better performance of the system.

2.LITERATURE REVIEW:

M. Patel et al. (2019) had conducted a study on Topology Optimization of Automotive Gear using FEA focusing on improving the efficiency of automotive gears by reducing their weight without compromising structural strength. The authors approached the problem by integrating computer-aided design (CAD) with Finite Element Analysis tools to simulate real-world loading conditions on the gear. Initially, a standard gear

model was created, and a static structural analysis was performed to determine stress distribution and deformation under applied torque. The results of this analysis helped identify regions within the gear body that experienced minimal stress. These low-stress regions were considered potential areas for material removal through topology optimization.

The optimization process involved systematically removing unnecessary material while ensuring that the remaining structure could still withstand operational loads. The optimized gear design showed a considerable reduction in weight compared to the original design, while the stress levels remained within permissible limits. The study also emphasized that improper material removal could lead to stress concentration and failure, highlighting the importance of careful design validation.

Ramadani. R et al. (2018) extends the concept of optimization by considering not only structural performance but also dynamic characteristics such as vibration. In this study, the authors aimed to design gear bodies that are both lightweight and capable of minimizing vibration during operation. The methodology involved defining objective functions that included mass reduction and vibration control. Using advanced optimization algorithms, the internal structure of the gear was modified to achieve these objectives. Finite Element Analysis was used extensively to evaluate both static and dynamic performance. Modal analysis was carried out to determine natural frequencies and vibration modes of the gear. The optimized design showed a reduction in mass along with improved vibration characteristics, resulting in quieter and smoother operation. This study highlights the importance of considering dynamic behavior in gear design, as excessive vibration can lead to noise, wear, and eventual failure. The integration of structural and dynamic optimization represents a significant advancement over traditional design methods.

Shahidurrehman H. Qurayshi, Prof. Mit Patel (2018) assessed various optimization techniques used in gear design. The paper compiles and analyzes findings from multiple research studies. The authors discussed different types of optimization methods, including size optimization, shape optimization, and topology optimization. Among these, topology optimization is identified as the most effective technique for achieving significant weight reduction while maintaining structural integrity. The review also covers the role of Finite Element Analysis in evaluating gear performance. Various software tools such as ANSYS and ABAQUS are discussed in terms of their capabilities and applications. The paper emphasizes the importance of accurate boundary conditions and material properties in obtaining reliable simulation results. In addition to summarizing existing research, the paper identifies gaps in the field, such as the lack of experimental validation and the high computational cost of optimization processes. This makes it a valuable resource for understanding the current state of research and guiding future studies.

Vaibhav Pimpalte, Prof. S.C. Shilwant (2017) applied Topology Optimization of Gears for two wheeler Gear Set Using Parametric Study focusing on improving gear design through parametric analysis. The authors investigated the effect of various design parameters, such as module, number of teeth, and face width, on gear performance. By systematically varying these parameters and analyzing the results using FEA, the study identified optimal design configurations. The findings showed that even small changes in geometric parameters can significantly affect stress distribution and deformation. This highlights the importance of careful parameter selection during the design process. The study provides practical insights into gear design and demonstrates the usefulness of parametric studies in achieving improved performance.

Liang et al. (2018) investigated topology optimization of transmission gearbox structures subjected to multiple loading conditions. The study aimed to minimize structural weight while maintaining sufficient stiffness and strength. A multi-load topology optimization methodology was implemented using Finite Element Analysis. The optimization process identified material regions that contributed minimally to load-carrying capacity and removed them from the design. The optimized gearbox structure exhibited reduced

mass and improved load distribution. Although focused on gearbox housings, the methodology provides valuable insights for topology optimization of gear components. The research demonstrated the effectiveness of topology optimization in achieving lightweight mechanical designs without compromising performance.

3. RESEARCH METHODOLOGY

3.1. Spur Gear Design:

A standard spur gear was designed by using SOLIDWORKS.

Table 1: Parameters of a spur gear

Parameters	Value
Number of Teeth	51
Pitch Circle Diameter	62.33mm
Module	1.22
Pressure Angle	20
Tooth Depth	3mm
Outer Diameter	65
Gear width	10mm
Addendum	1.1961mm
Dedendum	1.49552mm

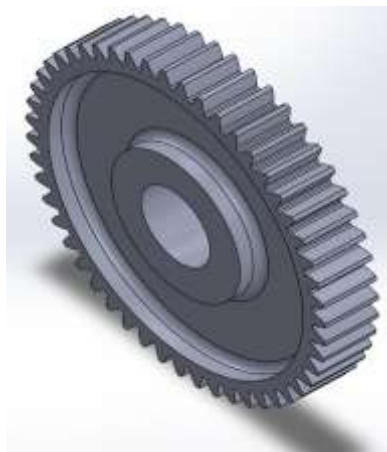

Fig.1: Spur Gear Design in Solid Works

3.2. Meshing:

Meshing is a critical step in Finite Element Analysis in which the model will be decomposed into small elements for better results. In this paper tetrahedral mesh was used as the geometry of spur gear is very complicated with the tooth profile. Tetrahedral elements can better fit the irregular and complicated geometry, and hence can represent the tooth profile of the gear better.

A mesh size of 4 mm was selected to maintain a balance between computational time, System support and accuracy. Compare to finer mesh, a 4 mm size mesh reduces the number of elements, which leads to faster simulation. Hence, the mesh can be classified as a moderately coarse (medium) mesh. It is slightly closer to coarse than fine, but still acceptable for engineering analysis where general deformation analysis is required without excessive computational cost.

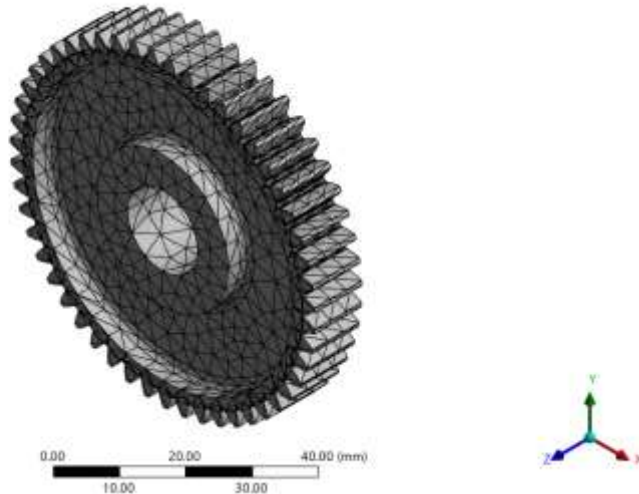

Fig.2: Meshing of a Spur Gear

3.3 Boundary Conditions:

In this study, the hub gear was fixed restricting all degrees of freedom to simulate the gear mounted on the shaft. A tangential force was applied on the gear tooth, representing the actual load transmitted during power transmission. The boundary conditions are same in all the materials to ensure a fair comparison.

This standard equation provides a quick estimate of the pitch and width of a gear needed to transmit a specified force. It makes use of pre-calculated values of the Lewis Form Factor. In other words, it says that the maximum permissible load per unit length of the contact surface is proportional to the gear's hardness (tested according to the Brinell or Rockwell test).

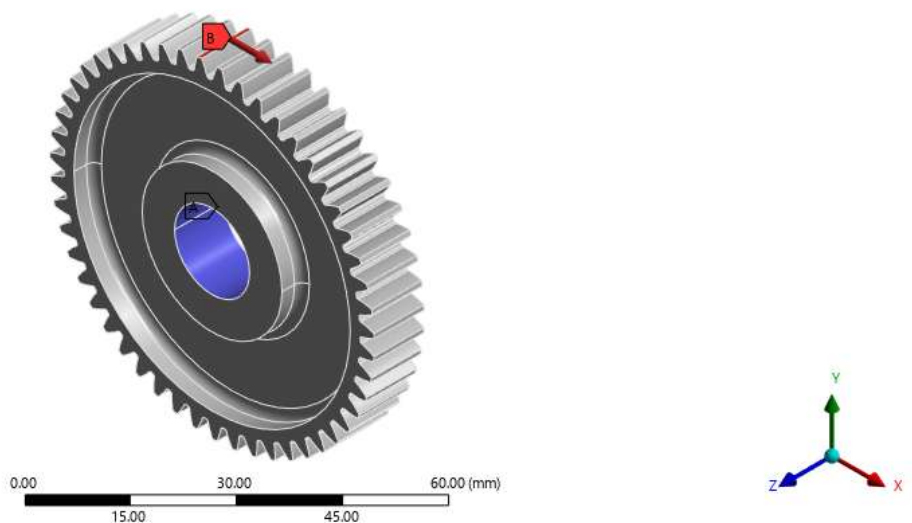

Fig.3: Boundary Conditions for a Spur Gear

A spur gear using standard design values was created, and its behavior under real working conditions was checked. Meshing was applied to break the model into small parts so that the analysis becomes more accurate. The gear was fixed at the Centre and applied force on the teeth to see how the load acts during rotation. After running the analysis, the deformations were analysed. Based on this, topology optimization was conducted, where the extra material was removed from the areas that are not carrying much load,

especially from the inner regions of the gear. In the end, an efficient gear design with required strength was selected, which shows how optimization helps in improving the performance in a simple and practical way.

4. RESULTS AND DISCUSSION

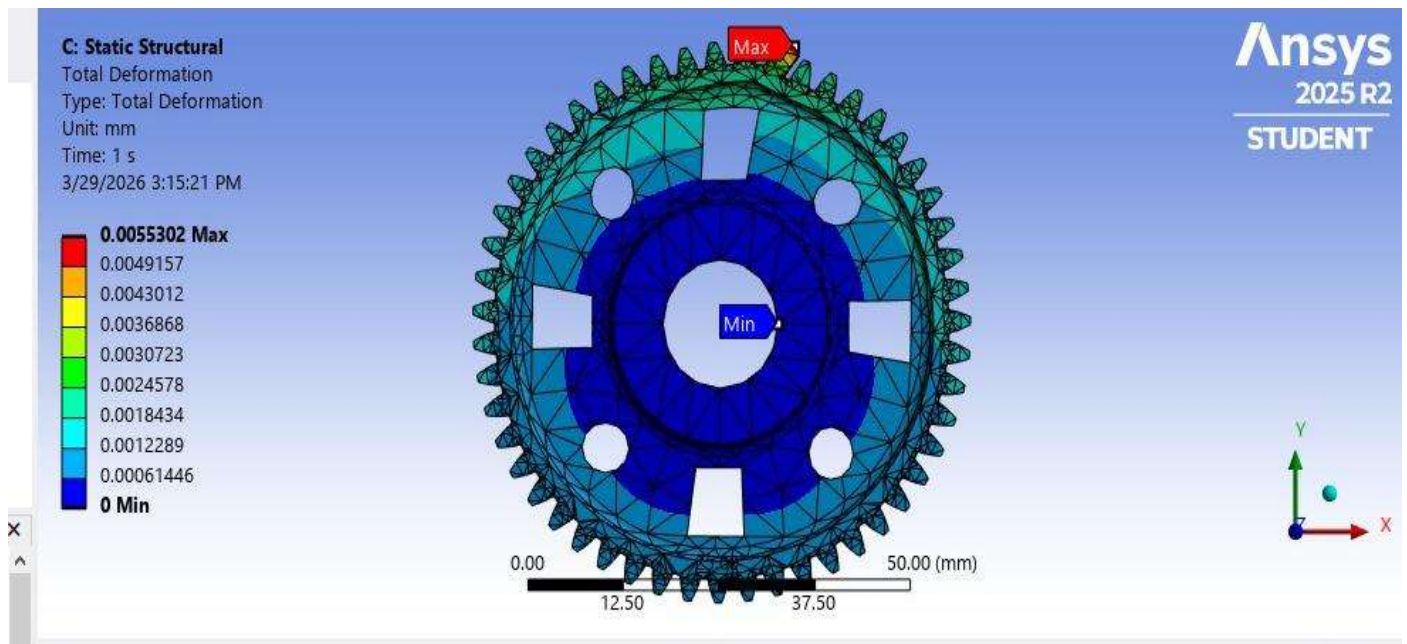

Fig.4: Hybrid hole gear design

This design uses both circular and square holes in the gear body. The aim is to reduce weight while maintaining structural strength.

Due to better material distribution, this design shows minimum deformation and performs best among all the models.

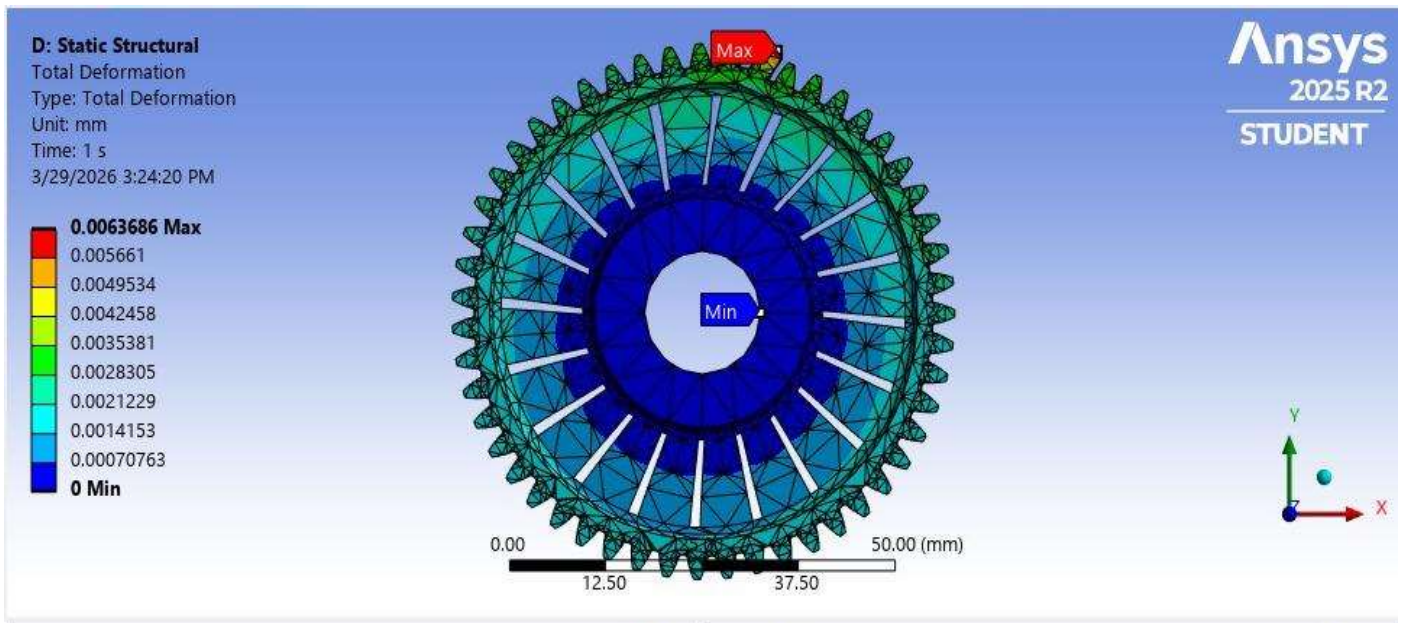

Fig.5: Radial spoke gear design

This design consists of multiple spokes connecting the inner hub to the outer rim. It reduces weight while maintaining a good load path. The deformation is moderate, making it a balanced and practical design.

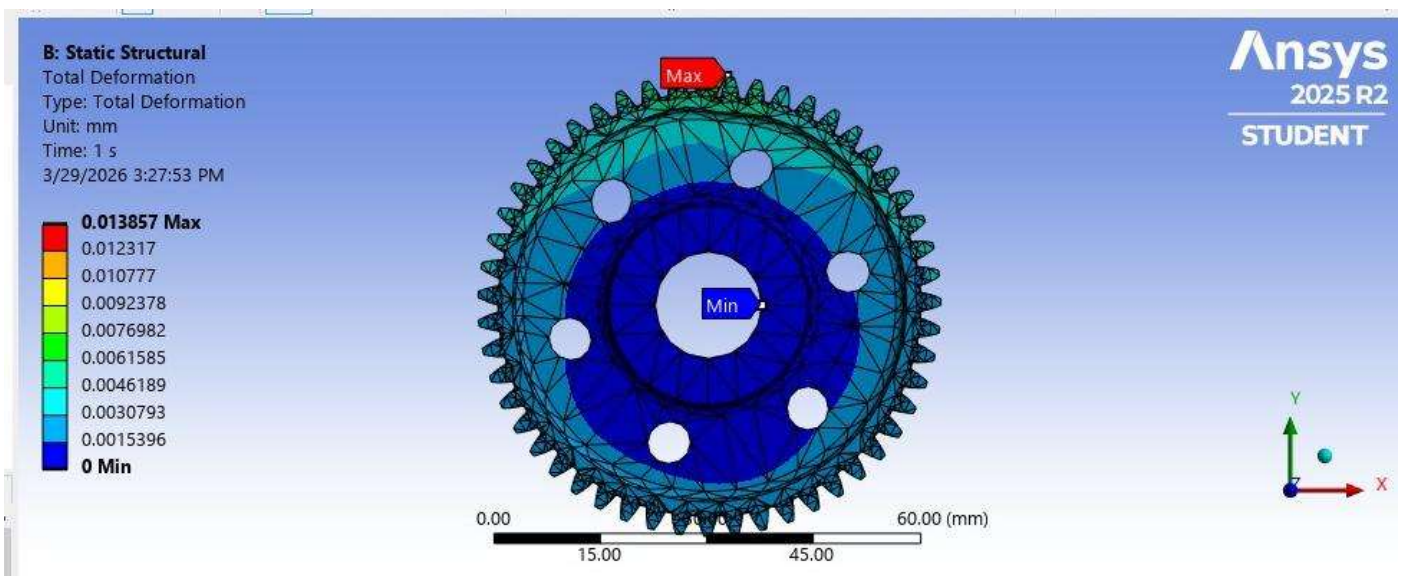

Fig.6: Circular perforated gear design

This design uses large circular holes to reduce material. Although it helps in weight reduction, it weakens the gear structure. This results in higher deformation, making it less suitable for heavy load applications.

Table 2: Results of Optimized Spur Gear

DESIGN	GEOMETRY TYPE	MAXIMUM DEFORMATION	MINIMUM DEFORMATION	AVERAGE DEFORMATION
Hybrid hole gear design	Circular + Square holes	0.00553	0	0.001317
Radial spoke gear design	Spoke Structure	0.00636	0	0.001899

Circular perforated gear design	Large circular holes	0.01385	0	0.002949
---------------------------------	----------------------	---------	---	----------

From the results, the Hybrid Hole Gear Design showed the least deformation of 0.00553 mm. This indicates that the design has better stiffness and can resist deformation effectively. The combination of circular and square holes helps in maintaining strength while still reducing some amount of weight.

The Radial Spoke Gear Design showed a slightly higher deformation of 0.00636 mm. This design provides a good balance between strength and weight reduction. The spokes help in transferring the load efficiently from the hub to the outer gear region, but due to reduced material, it shows slightly more deformation than the hybrid design.

The Circular Perforated Gear Design showed the highest deformation of 0.01385 mm. This is mainly because a large amount of material is removed in the form of circular holes, which weakens the structure. As a result, this design is not suitable for high load conditions.

Overall, the comparison clearly shows that proper material distribution plays an important role in improving gear performance. Designs with excessive material removal may reduce weight but can significantly reduce strength.

5.CONCLUSION

The internal design of the gear plays a major role in how it behaves when a load is applied. Among the three, the hybrid hole gear shows the best performance, as it has the least deformation. This means it is able to hold its shape better and is more stable when compared to the other designs. The reason for this is that the material is removed in a more balanced way, so even though the weight is reduced, the important areas of the gear are still strong enough to carry the load. The spoke gear also performs quite well and can be considered a good design. The spokes provide a clear path for the load to move from the centre to the outer teeth, which helps in maintaining strength even after some material is removed. However, its deformation is slightly higher than the hybrid design, which shows that it is a bit less stiff. On the other hand, the circular perforated gear shows the highest deformation, which clearly indicates that it is the weakest among the three designs. This is mainly because a large amount of material is removed in the form of holes, creating bigger empty spaces that reduce the stiffness of the gear. As a result, the gear bends more under the same load. From all these observations, it can be understood that simply reducing the weight of a gear is not enough to make it a better design. If too much material is removed without thinking about how the load will be carried, the gear becomes weak and less reliable. A good design should always maintain a proper balance between weight and strength. Another important point is that the way material is distributed inside the gear is more important than the amount of material removed. Designs that keep continuous support between the hub and the outer region perform better because they allow smooth transfer of load. Overall, this study shows that the hybrid gear design is the most effective among the three, as it provides better strength, less deformation, and improved stability. It also clearly highlights that careful and balanced design is necessary to achieve both good performance and weight reduction in mechanical components like gears.

6.REFERENCES

- [1] M. Patel, H. Valiulla, V. Khatod, B. Chaudhary, and V. Gondalia,- “Topology Optimization of Automotive Gear using FEA,” *International Journal of Recent Technology and Engineering (IJRTE)*, vol. 8, no. 4, pp. 1079–1084, Nov. 2019.
- [2] Ramadani. R, Belsak. A, Kegl. M, Predan. J & Pehan. S- “Topology Optimization Based Design of Lightweight and Low Vibration Gear Bodies”, *International Journal of Simulation Modelling*, Vol. 17, 2018.
- [3] Shahidurrehman H. Qurayshi, Prof. Mit Patel- “Topology Optimization of Automotive Gears Using FEA – A Review”, *International Journal of Scientific & Engineering Research (IJSART)*, Vol. 4, Issue 5, May 2018.
- [4] Vaibhav Pimpalte, Prof. S.C. Shilwant- “Topology Optimization of Gears from Two Wheeler Gear Set Using Parametric Study”, *IOSR Journal of Mechanical and Civil Engineering (IOSR-JMCE)*, 2017.
- [5] M. Liang, J. Hu, S. Li, and Z. Chen, “Topology Optimization of Transmission Gearbox under Multiple Working Loads,” *Advances in Mechanical Engineering*, vol. 10, no. 11, pp. 1–10, 2018.

Copyright & License:



© Authors retain the copyright of this article. This work is published under the Creative Commons Attribution 4.0 International License (CC BY 4.0), permitting unrestricted use, distribution, and reproduction in any medium, provided the original work is properly cited.