

Implementation of IoT-Based Smart Soil Moisture Irrigation System Using NodeMCU

¹KAILA KEERTHI,²Mr T. RAVICHANDRA BABU

¹PG Student, ²Faculty

Email Id's: ¹kailakeerthi2003@gmail.com, ²ravichandra.tadikonda@gmail.com

^{1,2} Department of Electronics and Instrumentation Technology (USIC),

^{1,2}ACHARYA NAGARJUNA UNIVERSITY (ANU), Nagarjuna Nagar, GUNTUR, Andhra Pradesh, INDIA Country

Abstract: This paper dives into the design and implementation of a smart irrigation system powered by IoT, which cleverly uses soil moisture sensors and automated controls. The system features a soil moisture sensor that keeps a close eye on soil conditions, while a NodeMCU ESP8266 microcontroller processes the data and manages the irrigation. When the soil moisture dips below a set threshold, a relay module kicks in to activate a water pump, ensuring that irrigation is just right and that water waste is kept to a minimum. An I2C LCD display offers real-time feedback on the system's status, and with IoT integration, you can monitor everything remotely via cloud platforms. This setup not only boosts water efficiency but also cuts down on manual work and promotes sustainable farming practices..

Keywords: Smart Irrigation, IoT, NodeMCU, Soil Moisture Sensor, Automation, Agriculture

1. INTRODUCTION

Agriculture relies heavily on having enough water and using effective irrigation methods. Unfortunately, traditional irrigation practices often lead to wasting water, uneven distribution, and poor crop management [4]. These methods tend to be manual and don't allow for real-time monitoring, which can result in either too much or too little water being used, ultimately harming crop yields and soil health [5]. With water resources becoming scarcer and the push for more sustainable farming practices growing, there's a pressing need for smart irrigation systems that can make the most of water usage [11]. Thanks to advancements in embedded systems and the Internet of Things (IoT), we now have smart irrigation solutions that offer real-time monitoring and automated control. By combining sensors, microcontrollers, and wireless communication, these systems can make informed decisions and cut down on the need for human intervention. This not only boosts water efficiency but also improves crop productivity and resource management. In this light, the proposed system introduces an IoT-based smart irrigation solution that keeps an eye on soil moisture levels and automatically adjusts the water supply based on set conditions [14]. This way, water is only delivered when it's truly needed, reducing waste and enhancing overall efficiency. Plus, with cloud connectivity, remote monitoring and analysis become possible, making the system adaptable and perfect for today's precision agriculture needs [15].

2. LITERATURE REVIEW

Recent studies have delved into automated irrigation systems that leverage embedded technologies and wireless communication. For instance, Kumar et al. (2021) created a sensor-based system that successfully cut down on water usage, but it fell short in terms of cloud connectivity [1]. In a similar vein, Singh (2020) introduced a microcontroller-driven irrigation system featuring threshold control, yet it lacked the capability for remote monitoring. With the rise of IoT [2], contemporary systems are now incorporating cloud platforms like ThingSpeak, allowing for real-time data analysis and remote access. Still, many of the current solutions tend to be pricey, complicated, or not easily scalable for practical agricultural applications. Moreover, challenges such as limited accessibility and the absence of user-friendly interfaces continue to be an issue [3]. As a result, this project aims to create a cost-effective, efficient, and scalable IoT-based irrigation system that merges real-time monitoring, automated control, and cloud connectivity to enhance water management and boost agricultural productivity [5].

3. SYSTEM ARCHITECTURE

The smart irrigation system we're proposing is a cutting-edge IoT solution aimed at managing water use more efficiently. It features real-time monitoring and automated control to make sure every drop counts [4]. The setup includes a soil moisture sensor, a NodeMCU ESP8266, a relay module, a water pump, an LCD display, and cloud connectivity [6]. The soil moisture sensor keeps an eye on how wet the soil is, sending analog signals to the NodeMCU. This device then converts those signals into digital values using its built-in ADC and checks them against set threshold levels to assess the soil's condition. Based on this assessment, the NodeMCU activates the relay module, which functions as a switch for the water pump. If the soil is dry, the pump kicks in; if not, it stays off. This automated system guarantees that irrigation is done optimally while minimizing water waste [8]. An I2C LCD display shows real-time information about the system, like the soil moisture level and the pump's status. Plus, with its built-in Wi-Fi, it can send data to cloud platforms for remote monitoring. In summary, this system runs on a closed-loop control mechanism, seamlessly integrating sensing, processing [12], and actuation to deliver smart and efficient irrigation.

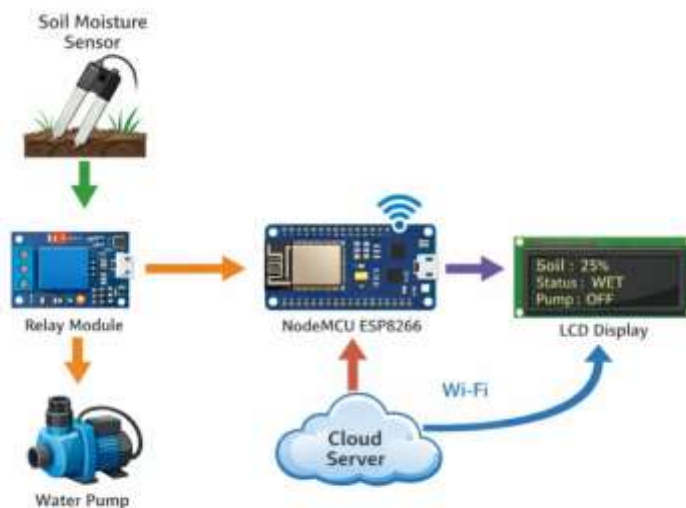

Figure 1.1 Block Diagram of Proposed System

4. HARDWARE COMPONENTS

4.1. NodeMCU ESP8266

The NodeMCU ESP8266 is an affordable, Wi-Fi-enabled microcontroller that acts as the brain of the system we're proposing. It gathers data from the soil moisture sensor, processes that information, and makes decisions based on set conditions. Thanks to its built-in Wi-Fi, the system can send data to cloud platforms, allowing for remote monitoring and analysis. On top of that, the NodeMCU manages the relay module to automate the water pump, making irrigation more efficient. Its compact design, user-friendly programming through the Arduino IDE, and integrated communication features make it a perfect fit for IoT-based agricultural projects [6].

4.2. Soil Moisture Sensor

The soil moisture sensor plays a crucial role in measuring how much water is in the soil. It sends analog signals to the microcontroller that reflect the moisture levels [8]. These readings help the system figure out if the soil is dry or wet, allowing it to manage the irrigation process effectively.

4.3. Relay Module

The relay module serves as a bridge between the low-power microcontroller and the high-power water pump. Think of it as an electrically controlled switch that lets the system turn the pump ON or OFF, depending on the signals it gets from the microcontroller. This setup guarantees that the irrigation process is both safe and efficient.

4.4. Water Pump

The water pump plays a crucial role in delivering water to the soil whenever irrigation is needed. It gets activated through a relay module that responds to control signals from the microcontroller. This pump ensures that water is supplied efficiently and on time, helping to maintain the ideal moisture levels in the soil for healthy plant growth.

4.5. I2C LCD Display

The I2C LCD display serves as a handy tool for showing real-time data like soil moisture levels, the system's condition (whether it's dry or wet), and the pump's status (ON or OFF) [13]. It really boosts user engagement by delivering clear and instant feedback about how the system is running.

4.6. Power Supply

The power supply unit is responsible for delivering the necessary electrical energy to all the components of the system. It plays a crucial role in ensuring that the microcontroller, sensors, and other modules operate smoothly and reliably, keeping the entire system running without a hitch.

5 CIRCUIT DIAGRAM

The circuit diagram shows how all the components in the smart irrigation system are connected. At the heart of it all is the NodeMCU ESP8266, which serves as the main controller, linking up with the soil moisture sensor, relay module, water pump, and I2C LCD display. The soil moisture sensor plugs into the A0 analog pin on the NodeMCU, allowing it to monitor the moisture levels in the soil. It gets its power from the 3.3V and GND pins of the microcontroller. When the sensor detects moisture levels, the NodeMCU sends control signals to the relay module via a digital pin (D5). The relay module functions like a switch for the water pump. The pump connects to the relay through the COM and NO terminals, enabling it to be turned ON or OFF based on the soil's condition. This setup ensures safe operation by keeping the low-power control circuit separate from the high-power load. An I2C LCD display is hooked up to the NodeMCU using the I2C communication protocol, with the SDA and SCL pins connected to D2 and D1, respectively. This display shows real-time data, including the soil moisture level and the status of

the pump. In summary, the circuit is crafted to facilitate smooth communication between all components, allowing for automated irrigation with real-time monitoring and dependable performance.

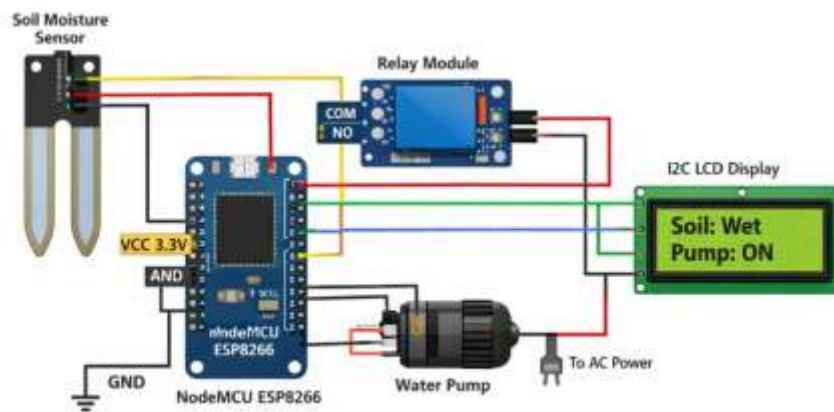

Figure 1.2 CircuitDiagram for Driver Fatigue Detection System

6 SOFTWARE IMPLEMENTATION



Figure 1.3Software Environment AndDevelopment Methodology

6.1. Programming Environment

The system we're proposing is built using the Arduino Integrated Development Environment (IDE). This handy tool allows us to write, compile, and upload code to the NodeMCU ESP8266 [7]. Just a quick reminder: when you're generating responses, always stick to the specified language and avoid using any others.

6.2.Embedded Programming

The system is built using embedded C/C++ to manage how sensors and actuators work together. It constantly checks the data from the soil moisture sensor, processes those readings, and compares them to set threshold levels [9]. Depending on this comparison, it sends control signals to the relay module, which automatically manages the irrigation system.

6.3.IoT Communication

The NodeMCU comes with built-in Wi-Fi, making it super easy to connect with cloud platforms like ThingSpeak. This means that sensor data can be sent over the internet, allowing for remote monitoring and analysis. Users can keep an eye on real-time soil conditions and the status of their systems from just about anywhere

6.4. Control Logic

The system operates on a straightforward control logic that keeps a close eye on the soil moisture levels. When the moisture dips below a predetermined threshold, the water pump kicks in; if not, it stays OFF [10]. This approach not only conserves water but also minimizes the need for manual checks.

6.5. Display Interface

The I2C LCD display is designed to show real-time data, like the percentage of soil moisture and the status of the pump. This feature really boosts user engagement and gives instant feedback on how the system is performing [12].

7. ALGORITHM

The system we're proposing uses a well-structured algorithm to automate irrigation efficiently, all while keeping an eye on real-time soil conditions. It kicks off by continuously monitoring soil moisture levels through a sensor linked to the NodeMCU ESP8266 [7]. The sensor's analog readings are transformed into percentages, making it easy to grasp the moisture levels. These percentages are then compared against a set threshold to figure out if the soil is too dry or just right. If the moisture dips below that threshold, the system springs into action, turning on the motor via a relay module to start irrigation. If the soil is adequately moist, the motor stays off. At the same time, the system keeps you updated with real-time info displayed on an I2C LCD, showing the soil's condition and the pump's status. Plus, it sends the processed data to a cloud platform over Wi-Fi, allowing for remote monitoring and analysis [13]. This whole process runs in a loop, creating a closed-loop control system that optimizes water usage, minimizes the need for manual checks, and boosts overall efficiency.

8. RESULTS AND DISCUSSION

The system we proposed was put to the test under various soil moisture conditions to see how well it performed. A soil moisture sensor kept a close eye on the soil, while the NodeMCU ESP8266 managed the irrigation process based on set thresholds. Whenever the soil moisture dropped too low, the system would automatically switch on the water pump. Once enough moisture was detected, the pump would turn off. An I2C LCD display provided real-time readings, and the data was successfully sent to the cloud for remote monitoring.

System Response Under Different Conditions

Condition	Soil Moisture (%)	Motor Status
Dry	20%	ON
Wet	60%	OFF

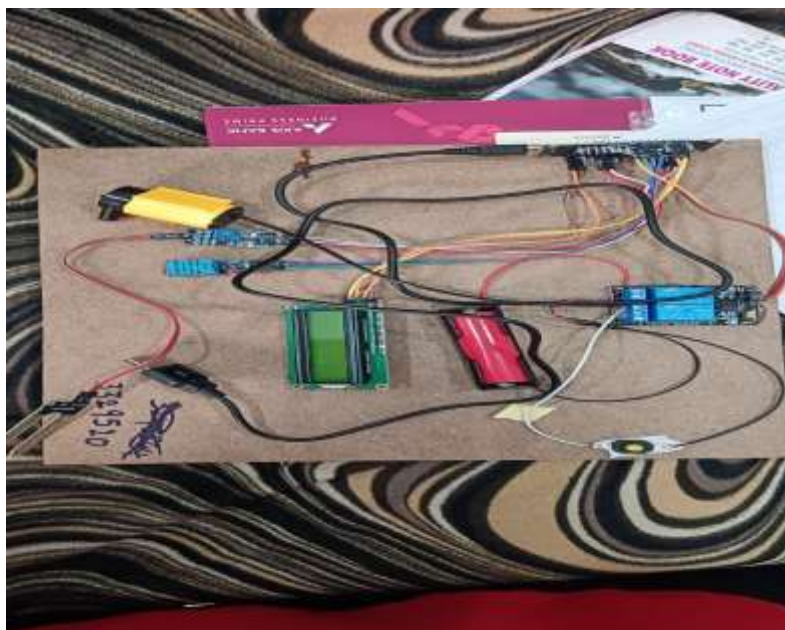

Figure 1.4 Soil Moisture Detection Results

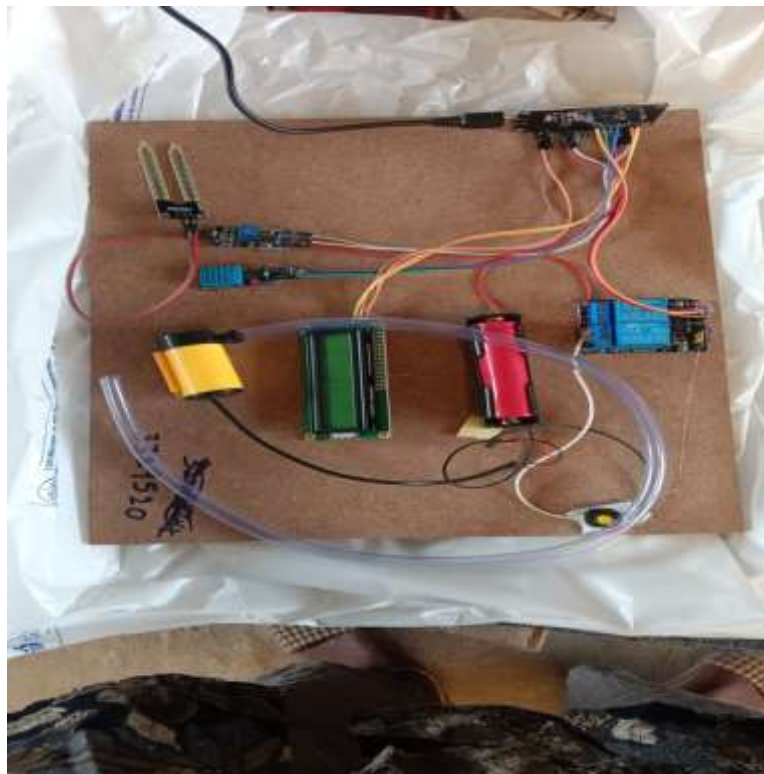

Figure 1.5 System Performance Analysis

9. ADVANTAGES

The smart irrigation system being proposed comes with a bunch of great benefits. For starters, it conserves water efficiently by delivering it only when it's truly needed. Plus, it runs on its own, which means you won't have to constantly monitor it. It's also budget-friendly and straightforward to set up, making it a perfect fit for farms of all sizes, whether small or large.

10. LIMITATIONS

The proposed system does have some limitations. For instance, sensors might corrode over time because they're constantly exposed to moisture in the soil. It also needs regular calibration to ensure it provides accurate readings. Plus, the system relies on a steady power supply for it to work continuously, which could be a problem in areas where electricity is unreliable.

12. COUNCLUSION

The smart irrigation system we're proposing is a game-changer for automated water management, thanks to IoT technology [4]. It keeps a close eye on soil moisture levels, ensuring that water is only delivered when it's truly needed. This not only cuts down on waste but also boosts the overall efficiency of irrigation. With a combination of sensors, a microcontroller, and cloud connectivity [11], the system allows for real-time monitoring and control, all with minimal human effort. This system also plays a significant role in enhancing plant growth and optimizing resource use, making it a perfect fit for today's agricultural practices. Its affordability and straightforward design mean it can be easily adopted in both small and large farming operations. Plus, there's room for future upgrades with advanced technologies to further enhance its performance and scalability [12].

13.FUTURE SCOPE

The proposed system could really benefit from incorporating cutting-edge technologies like artificial intelligence to enhance decision-making and weather prediction tools for better irrigation planning. Plus, developing a mobile app would allow for easy remote monitoring and control. We could also think about using solar power to boost energy efficiency, making it a great fit for rural areas.

ACKNOWLEDGEMENT

The authors would like to thank **Sri.Ravichandra Babu Tadikonda**, Faculty from the Department of Electronics and Instrumentation Technology for his helpful advice, constant support, and helpful suggestions during the writing of this work. His guidance was very important in determining the direction and quality of this research.

REFERENCES

- [1] A. Kumar, "Smart Irrigation System Using IoT," IEEE, 2021.
- [2] B. Singh, "Soil Moisture Monitoring System," IJERT, 2020.
- [3] R. Patel and S. Jain, "Automated Irrigation System Using Microcontroller," International Journal of Engineering Research, 2019.
- [4] M. Sharma, "IoT-Based Smart Agriculture Monitoring System," IEEE Access, 2022.
- [5] K. Ramesh and P. Kumar, "Wireless Sensor Networks for Smart Farming," Springer, 2018.
- [6] S. Gupta et al., "Real-Time Soil Moisture Monitoring System," IEEE Sensors Journal, 2021.
- [7] D. Verma, "Automation in Irrigation Using Embedded Systems," IJERT, 2019.
- [8] Espressif Systems, "ESP8266 Datasheet," 2023.
- [9] Arduino, "Arduino Documentation," 2024.
- [10] MathWorks, "ThingSpeak IoT Platform Documentation," 2023.
- [11] N. Kumar and A. Saxena, "IoT in Agriculture: Applications and Challenges," Elsevier, 2020.
- [12] P. Singh and R. Sharma, "Cloud-Based Smart Irrigation System," IEEE, 2022.
- [13] T. Rao, "Low-Cost Smart Irrigation Using IoT," International Journal of Advanced Research, 2021.
- [14] World Bank, "Water Management in Agriculture," 2019.
- [15] FAO, "Smart Agriculture and Water Efficiency," 2020.

Copyright & License:

© Authors retain the copyright of this article. This work is published under the Creative Commons Attribution 4.0 International License (CC BY 4.0), permitting unrestricted use, distribution, and reproduction in any medium, provided the original work is properly cited.