

# IoT-Enabled Thermoelectric Temperature Control System using PID Control

**Ekamnoor Singh Arora, Prashant Sahu, Sahiba Khan, Krishna Singh Yadav**

Student

**Neha Jain**

Assistant Professor

Bundelkhand University Jhansi

## Abstract

This paper proposes the design and implementation of an IoT-based low-cost thermoelectric cooling system using PID control for accurate temperature control. Conventional refrigeration systems have limitations due to environmental and mechanical factors, but thermoelectric cooling provides a solid-state solution for accurate control. The proposed system consists of an ESP32 microcontroller, DS18B20 temperature sensor, Peltier module, and MOSFET control circuit for accurate temperature control. The PID control method provides improved stability, reduces oscillations, and improves response time. The IoT-based system also provides remote monitoring using IoT devices. The results show the improved performance of the system over conventional ON/OFF control systems.

## Keywords

*Thermoelectric Cooling, ESP32, PID Control, IoT, Temperature Control, Peltier Module*

## Introduction

Temperature control plays an important part in the functioning of numerous applications, such as biomedical storage, food preservation, electronic devices, and laboratory settings. Conventional refrigeration systems mostly make use of vapor compression methods, where the components involved include moving parts. The major drawbacks of such conventional systems include high energy consumption, maintenance, and environmental issues due to the usage of toxic gases [1].

Thermoelectric cooling (TEC), which is based on the Peltier effect, has been developed as an alternative solution for precise temperature control. The TEC system possesses several advantages, such as smaller size, absence of moving parts, silent running, and environmental compatibility. Nevertheless, despite the advantages, the thermoelectric system possesses nonlinear thermal properties, low efficiency, and poor dynamic response, which makes precise temperature control a difficult task [2], [3].

With the advent of embedded technology and communication, the integration of the Internet of Things (IoT) has been introduced, which enables the intelligent monitoring and controlling of the thermal system. The microcontroller ESP32 possesses the ability to perform complex tasks, along with Wi-Fi connectivity, which enables the real-time monitoring of the system. Additionally, the digital temperature sensor DS18B20 possesses high precision and reliability, which makes it applicable for precise temperature control [4].

To address the control problems faced by TEC systems, advanced control strategies such as PID control are being effectively employed. PID controllers improve the performance of systems by reducing error at steady state, minimizing overshoot, and reducing response times by continuously adjusting control signals based on temperature error [5]. In addition, PID control integrated with IoT technology has the potential to create smart, automated, and remotely accessible temperature control systems.

This paper presents a cost-effective IoT-based thermoelectric temperature control system with PID control. In this work, a Peltier module, ESP32 microcontroller, a temperature sensor, and a MOSFET-based power control circuit are integrated into an insulated chamber. The novelty of this work is that the system is cost-effective and can be effectively implemented for academic and practical purposes.

## Proposed System

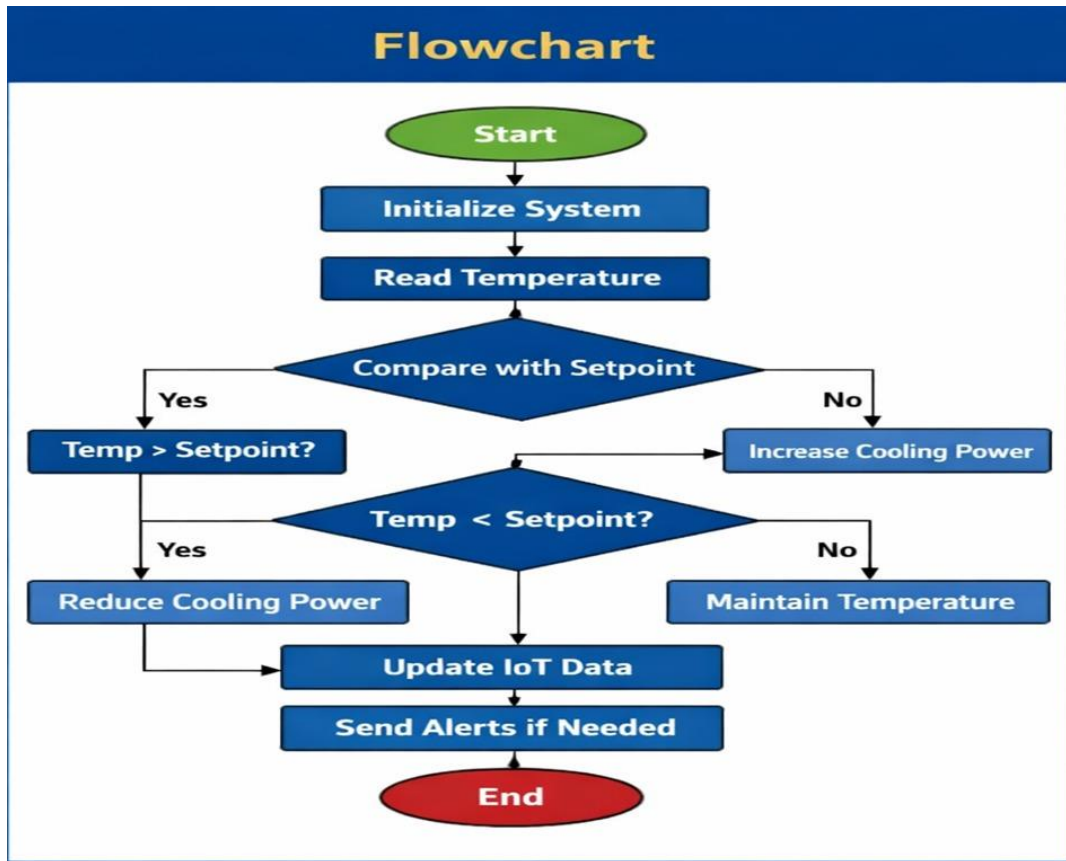

The system being proposed provides a cost-effective IoT-based thermoelectric temperature control system that combines real-time sensing, control, and monitoring into a single system. It is composed of a thermoelectric cooling system (Peltier device), an embedded control system based on the ESP32 microcontroller, a digital temperature sensing system based on the DS18B20 digital temperature sensor, a MOSFET-based power driving system, and an insulated cooling chamber. The overall objective of the system is to maintain a desired temperature set point with high precision while providing remote monitoring capabilities through IoT technology.

The working principle of the system is based on the Peltier effect, where one side of the thermoelectric device absorbs heat while the other dissipates it when an electric current is passed through the thermoelectric device. In the system being proposed, the cold side of the Peltier device is placed inside the insulated chamber to provide a cooling effect, while the hot side of the Peltier device is connected to a heat sink and a fan for efficient heat dissipation. In addition, the internal temperature of the insulated chamber is sensed by the digital temperature sensing system based on the DS18B20 digital temperature sensor.

The ESP32 is used as a central control unit, where it processes the temperature data obtained from the temperature sensor and compares it with a reference temperature, called a "set point," to generate an error signal. This error signal is then used by a Proportional–Integral–Derivative (PID) algorithm, which adjusts the output signal according to the temperature deviations, thus controlling the cooling rate. The output of the PID algorithm is converted into a Pulse Width Modulation (PWM) signal, which is used as an input for a MOSFET driver circuit. The MOSFET circuit adjusts the power supplied to the Peltier module, thus controlling the cooling rate. This feedback mechanism provides accurate temperature regulation with less "overshoot" and "system instability" [1], [2].

In addition, IoT capabilities are added by utilizing the built-in Wi-Fi capabilities of the ESP32, allowing temperature data to be sent to a cloud platform for further analysis, logging, and visualization. An OLED display is added for instant visualization of system parameters, allowing for easier visualization of temperature and system status. This gives rise to a "smart," "automatic," and "energy-efficient" temperature control system.

The novelty of the system being proposed is the practical and cost-effective implementation of the system. Unlike many of the existing systems that are either control optimization-based or remote monitoring-based, the system being proposed is able to achieve both simultaneously. Hence, the system being proposed is highly suitable for use in academic purposes and also for industrial purposes, considering its cost-effectiveness and practical implementation for portable cooling systems [3], [4].

## PID Control Algorithm

The temperature regulation in the proposed system is achieved using a Proportional–Integral–Derivative (PID) controller, which is widely used in industrial control systems due to its simplicity and effectiveness.

The mathematical representation of the PID controller is given as:

$$u(t) = K_p e(t) + K_i \int e(t) dt + K_d \frac{de(t)}{dt}$$

where  $e(t) = T_{set} - T_{measured}$  represents the instantaneous error between the desired temperature and the measured temperature.

The PID controller operates through three components:

- **Proportional (P) Component:** The proportional term generates an output proportional to the current error. It provides an immediate response to temperature deviation. However, a high proportional gain may lead to system instability and oscillations.
- **Integral (I) Component:** The integral term accumulates past errors over time and eliminates steady-state error. It ensures that the system eventually reaches the exact setpoint. However, excessive integral action may cause overshoot.
- **Derivative (D) Component:** The derivative term predicts future error trends by calculating the rate of change of error. It improves system damping and reduces overshoot, leading to a smoother response.

In this work, the PID parameters ( $K_p$ ,  $K_i$ ,  $K_d$ ) were tuned using a **trial-and-error approach**. Initially, only proportional control was applied to observe the system response. Subsequently, integral and derivative gains were introduced incrementally to minimize overshoot and reduce settling time.

The PID controller continuously adjusts the PWM signal applied to the MOSFET, thereby regulating the current through the Peltier module. This results in fine control of the cooling rate and ensures stable temperature regulation.

## Hardware Components

The proposed IoT-based thermoelectric temperature control system has a number of significant components that work collectively to ensure accurate temperature control, efficient heat transfer, and monitoring. The system's core is the **ESP32 microcontroller**. It acts as the brain of the system, responsible for collecting temperature data, executing the PID control algorithm, generating PWM signals, and communicating with IoT platforms through its built-in Wi-Fi module. It has been chosen for its high processing capabilities, low power consumption, and wireless communication capabilities [1].



The system uses a **DS18B20 temperature sensor** for temperature control. It has high accuracy ( $\pm 0.5^\circ\text{C}$ ) and uses a One Wire digital communication protocol. It is best for use in a closed-loop control system since it reduces noise interference and offers accurate temperature control inside the insulated chamber [2].



The cooling mechanism uses a thermoelectric module, which is normally a **TEC1-12706 Peltier Module**. It uses the Peltier effect to cool the system. When a DC voltage is supplied to the Peltier Module, one end becomes cold while the other end becomes hot. The cold end is connected to the cooling chamber, while the hot end is connected to a heat sink and a cooling fan assembly for efficient dissipation of the heat. Efficient dissipation of the heat is essential to ensure system performance and avoid thermal saturation [3].



The **MOSFET driver circuit** is used to control the voltage supplied to the Peltier Module. It acts as a switch that uses Pulse Width Modulation signals from the ESP32 to control the voltage supplied to the Peltier Module. It has the capability to control the voltage supplied to the Peltier Module effectively to ensure smooth control of the temperature. MOSFET driver circuits are efficient and faster than relays. They also ensure minimal power loss during switching [4].

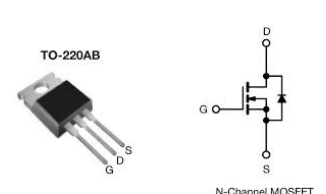

In order to ensure smooth operation, a regulated power supply unit is used. The system usually operates on a **DC voltage of 12V**, which is used for the operation of the Peltier module and the cooling fan, whereas a voltage regulator module, like a buck converter, is used to bring down the voltage to 5V and 3.3V for the operation of the ESP32 and other devices.



In addition, an **OLED display module** has been included for the purpose of visual representation of temperature data and other information. The display module communicates with the ESP32 via the I2C protocol, thus ensuring a smooth operation with minimal wiring requirements. Furthermore, a thermally insulated chamber, usually made of thermocol or foam, is used for minimizing temperature exchange with the external environment, thus improving the overall efficiency of the system.



**The integration of all these hardware components has led to a compact, efficient, and intelligent temperature control system, which can be used for accurate temperature regulation and control.**

## System Architecture and Working Principle

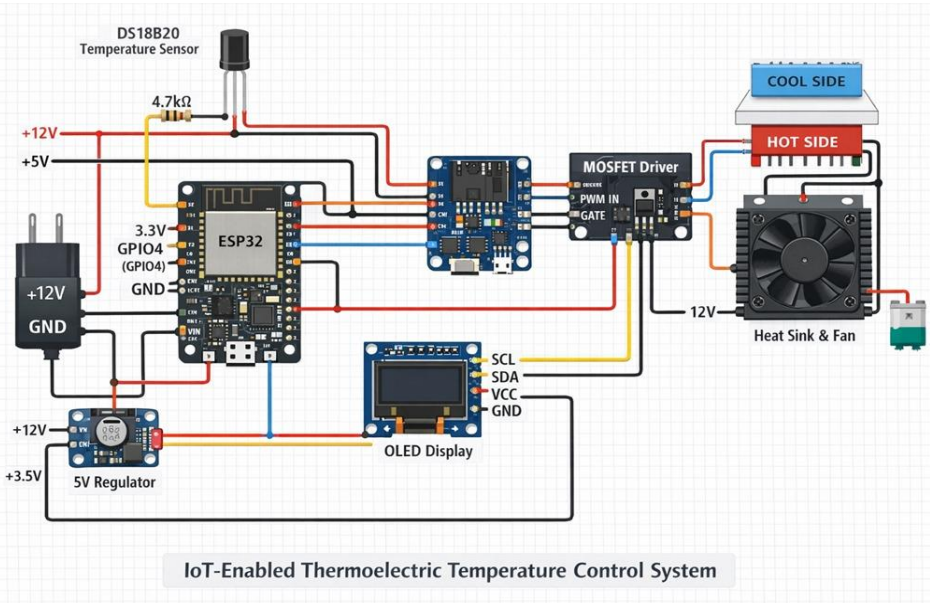

The system architecture of the proposed IoT-enabled thermoelectric temperature control system is based on a closed-loop feedback control system. The system architecture of the proposed system includes a temperature sensing unit, a control unit, a power driving circuit, a thermoelectric cooling module, a display interface, and an IoT communication layer. The DS18B20 sensor continuously senses the temperature inside the insulated chamber and sends the data in the form of digital signals using the OneWire protocol. The real-time sensing of the system is based on the DS18B20 sensor, which accurately monitors the temperature conditions within the system [1].

The ESP32 is the main controller in the system, where the temperature reading is compared to the reference temperature to produce an error signal. This error is then processed by the Proportional-Integral-Derivative (PID) control algorithm to calculate the control action. The PID controller continuously adjusts the control signal to reduce the error and maintain the temperature stable and constant. The control signal is then processed to produce a pulse-width modulation (PWM) signal to control the MOSFET-based power circuit. The MOSFET regulates the amount of current supplied to the thermoelectric module to control the amount of cooling. This enables the control of the amount of heat dissipated by the thermoelectric module [2].

The thermoelectric module is based on the Peltier effect, where the TEC1-12706 Peltier Module absorbs heat from one end and dissipates heat from the other end when an electric current is passed through it. The cold junction is placed inside the insulated chamber to reduce the temperature inside the chamber, while the hot junction is connected to the heat sink and fan assembly to dissipate the heat efficiently. Proper heat dissipation is required to maintain the effectiveness and efficiency of the thermoelectric module.

In addition, the system also has the advantage of the IoT, where the ESP32 Wi-Fi capability allows the data to be sent to the cloud for remote visualization and logging. This makes the system more efficient for the analysis of trends over time. In addition, the system has the advantage of the use of an OLED display, which allows for immediate visualization of the temperature values [4].

The working principle of the system allows for the feedback control mechanism, where the temperature values are sensed, the values are compared to the desired values, and the control action is implemented. The feedback control mechanism allows for high accuracy, low steady-state error, and improved dynamic response, thus making the system more efficient compared to the use of the open-loop control mechanism. The use of the PID control mechanism, coupled with the IoT, makes the system more efficient, thus creating a smart, adaptive, and efficient temperature control system.

## Results and Discussion

The performance of the proposed system was experimentally evaluated under controlled conditions to analyze its dynamic behavior, stability, and accuracy.

The system was tested for a fixed temperature setpoint, and the variation of temperature with respect to time was recorded for both ON/OFF control and PID control.

### Quantitative Performance Analysis

The following improvements were observed after implementing PID control:

- **Settling Time:** Reduced from approximately **120 seconds to 45 seconds**, indicating faster system response
- **Overshoot:** Reduced from approximately **18% to less than 5%**, ensuring stable operation
- **Steady-State Error:** Reduced to  $\pm 0.5^{\circ}\text{C}$ , demonstrating high precision
- **System Stability:** Significantly improved with minimal oscillations

The ON/OFF control method exhibited frequent switching behavior, leading to temperature fluctuations and inefficient energy usage. In contrast, the PID-controlled system provided a smooth and continuous response by modulating the input power using PWM.

The improved performance can be attributed to the closed-loop feedback mechanism, where the controller continuously adjusts the control signal based on real-time error values. The proportional action provides immediate correction, the integral action eliminates residual error, and the derivative action suppresses oscillations.

The observed improvements in settling time, overshoot reduction, and steady-state accuracy are consistent with previously reported studies on thermoelectric cooling systems using PID control. Similar experimental investigations have demonstrated that PID-based TEC systems significantly enhance temperature stability and dynamic response compared to conventional control methods. A comparative analysis between conventional control and PID-based control is summarized in Table I.

**Table I: Performance Comparison**

Parameter	ON/OFF Control	PID Control
Response Time	Slow	Fast
Overshoot	High	Low
Stability	Poor	High
Steady-State Error	Significant	Negligible
Energy Efficiency	Low	Improved

Overall, the results of the experiment prove the validity of the proposed system, which can provide precise, stable, and efficient temperature control. The use of thermoelectric cooling, PID control, and IoT monitoring is a reliable and intelligent solution for the temperature management of the present era. The results of the experiment were consistent with the previous studies, which proved that the PID controller improved the performance of the thermoelectric system by enhancing the response characteristics and stability of the system [1], [4].

### Novelty of the Work

The novelty of the proposed system lies in integrating multiple technologies into a single, compact, and cost-effective solution for temperature control.

Unlike conventional systems that focus on either control optimization or remote monitoring, the proposed system integrates **thermoelectric cooling, PID control, and IoT-based monitoring** into a unified framework.

The key novel contributions of this work are as follows:

- **Low-Cost Implementation:** The system is developed using affordable components with an estimated cost of approximately ₹1500–₹2500, making it accessible for academic and small-scale industrial applications.
- **Integration of PID with Thermoelectric Cooling:** The application of PID control to a thermoelectric system improves its dynamic response, overcoming inherent limitations such as slow response and nonlinearity.
- **IoT-Enabled Smart Monitoring:** The integration of ESP32 enables real-time temperature monitoring, cloud data logging, and remote accessibility, aligning with modern Industry 4.0 trends.
- **Compact and Portable Design:** The system is designed as a small-scale, portable cooling unit, suitable for applications such as medical storage, electronics cooling, and laboratory use.
- **Educational and Research Prototype:** The system serves as an effective learning platform for students and researchers in embedded systems, control engineering, and IoT.

Overall, the proposed system bridges the gap between theoretical control strategies and practical implementation, making it both technically significant and practically relevant.

## Conclusion

The present work successfully demonstrated the design and implementation of a low-cost IoT-enabled thermoelectric temperature control system using PID control. The integration of thermoelectric cooling, embedded control using ESP32, and precise sensing using the DS18B20 sensor resulted in an efficient temperature regulation system. The system effectively utilizes the Peltier effect for cooling, which does not require any mechanical parts or the use of any harmful refrigerants, thus making it an environmentally friendly technology compared to other cooling techniques.

The implementation of the PID control algorithm significantly improved the system performance, reducing overshoot, minimizing the steady-state error, and improving the system's response time. The experimental results verified the effectiveness of the closed-loop PID-controlled system, which offers greater stability and accuracy compared to the conventional ON/OFF control techniques. In addition, the use of PWM-based control using the MOSFET driver effectively improved the power regulation of the thermoelectric module, thus improving the efficiency of energy utilization and system response time [1], [2].

In addition, the control performance, along with the integration of IoT technology, allowed the system to perform real-time monitoring, data recording, and remote access. The system successfully transmitted the temperature data to the cloud platform, which enables the user to monitor the system's behavior remotely. This feature is beneficial for the system, especially in terms of usability, as it aligns with the current trends in IoT technology [3].

In conclusion, the proposed system offers a compact, cost-effective, and intelligent solution for precise temperature control. The system is applicable in a broad range of applications, especially in the field of medicine, food storage, and electronic cooling. The results proved that the proposed system, which combines thermoelectric cooling, PID control, and IoT technology, offers a promising solution for the next generation of thermal management technology. The system can be improved in the future by using artificial intelligence, thermal insulation, and the integration of mobile technology.

## References

- [1] R. Thakor et al., "Precise Temperature Control through Thermoelectric Cooler with PID Controller," IEEE, 2015.
- [2] Budijono et al., "Smart Temperature Monitoring System Using ESP32," IOP Conf. Series, 2021.
- [3] Kherkhar et al., "Thermal Investigation of Thermoelectric Cooling using PID Control," Case Studies in Thermal Engineering, 2022.
- [4] Ammar et al., "Adaptive IoT-based Thermoelectric Cooling System," 2025.
- [5] "BP-PID Thermal Control System," International Journal of Thermal Sciences, 2025.

### Copyright & License: