

IOT BASED SMART VEHICLE START USING FACE DETECTION

¹Bagal Ajay Ashok, ²Phate Pruthviraj Hanmant, ³Pujari Mahesh Sidgonda, ⁴Prof.Y. S. Ghodake

¹²³B.Tech Student, ⁴Project Guide

¹²³⁴Department of Electronics and Telecommunication Engineering,

¹²³⁴Karmayogi Institute of Technology, Shelve, Pandharpur, India.

Abstract : The increasing number of vehicle theft cases has created a demand for advanced security systems. This paper presents an IoT-based smart vehicle start system using face detection technology to enhance vehicle security. The system uses a Raspberry Pi integrated with a USB camera to capture real-time facial images. These images are processed using OpenCV for face recognition. If the detected face matches the authorized user, the system sends a signal through GPIO pins to the motor driver, which activates the vehicle ignition mechanism. If the face is not recognized, the system denies access. The proposed system eliminates the need for physical keys and improves security by allowing only authorized users to start the vehicle.

IndexTerms - IoT, Face Detection, Raspberry Pi, OpenCV, Smart Vehicle, Security System

INTRODUCTION

With the advancement in IoT and embedded systems, vehicle security systems are becoming smarter and more efficient. Traditional vehicle ignition systems rely on physical keys, which can be lost or duplicated. The proposed smart vehicle start system uses face detection technology to improve security. The Raspberry Pi acts as the main controller, connected with a USB camera, motor driver, and motor. When the system is activated, the camera captures the image of the user. If the image matches the authorized dataset, the vehicle starts; otherwise, access is denied.

NEED OF THE STUDY.

Vehicle theft is a major issue in modern society. Traditional locking systems are not fully secure and can be bypassed easily. A biometric-based system like face detection provides higher security as facial features are unique. This system reduces the chances of unauthorized access and eliminates dependency on physical keys.

THEORETICAL FRAMEWORK.

Face detection and recognition technologies are widely used in security applications. OpenCV provides efficient algorithms for image processing and face recognition. Raspberry Pi, being a low-cost and powerful computing device, is suitable for implementing such systems. The integration of IoT and image processing enables real-time monitoring and decision-making, making the system intelligent and automated.

SYSTEM DESIGN.

The system consists of Raspberry Pi, USB camera, motor driver, and motor. The Raspberry Pi captures images and processes them to detect faces. Based on recognition results, it controls the motor driver to start or stop the vehicle.

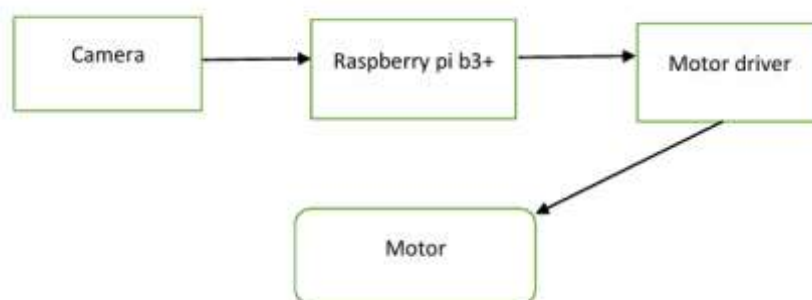

Figure 1: Block Diagram of Smart Vehicle Start System

4.1 Hardware Design.

The system includes the following components:

- **Raspberry Pi B3+** – Main controller
- **USB Camera** – Captures user image
- **Motor Driver (L298N)** – Controls motor
- **Motor** – Represents vehicle ignition
- **Connection Wires** – For interfacing

4.2 Working of the System.

When the system starts, the Raspberry Pi activates the USB camera to capture the user’s image. The captured image is processed using OpenCV. If a match is found, the Raspberry Pi sends a signal to the motor driver using GPIO pins. The motor driver then activates the motor, simulating vehicle ignition. If no match is found, the motor remains OFF, ensuring security.

RESULTS AND DISCUSSION.

The system was tested under real-world conditions.

5.1 Hardware Implementation.

The system was successfully implemented using Raspberry Pi and camera module. The hardware setup accurately captured images and processed them for face detection.

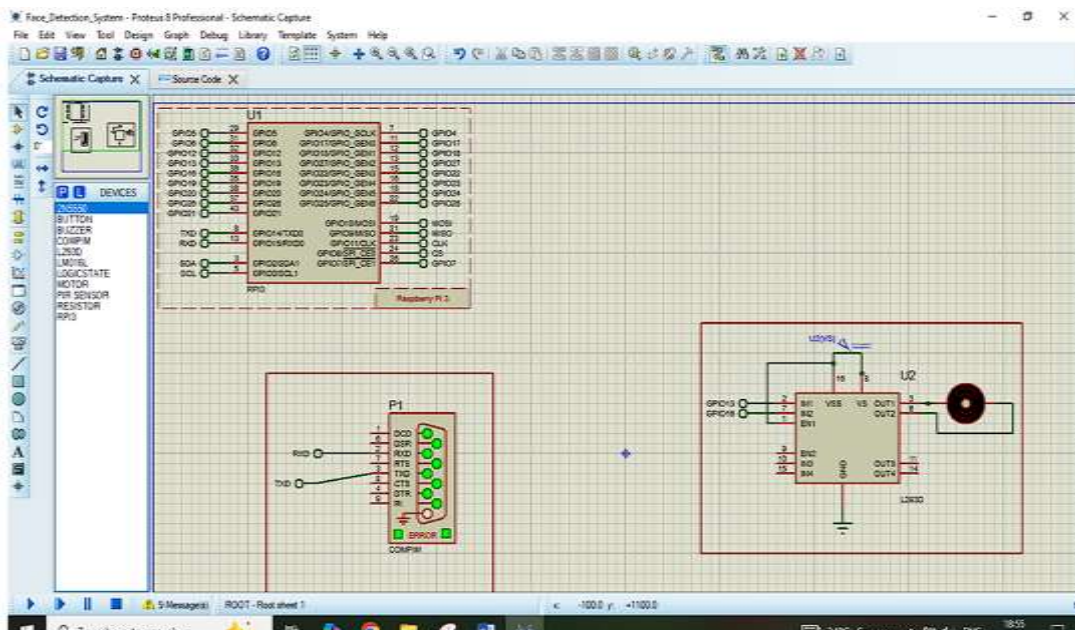

Figure 2: Simulation of Circuit

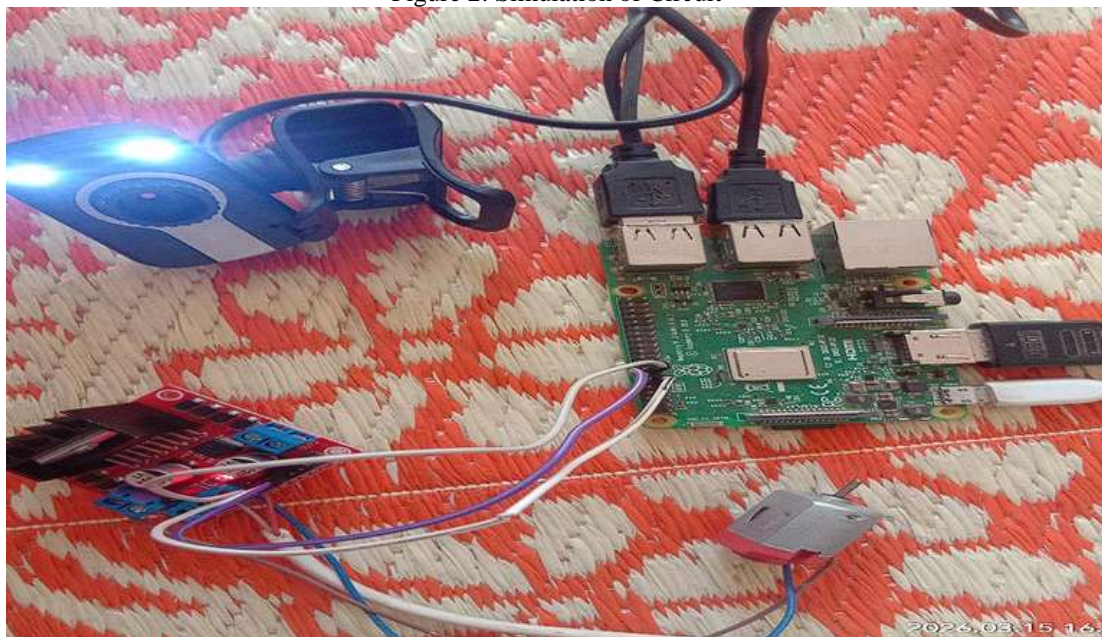

Figure 3: Hardware Prototype

5.2 System Performance.

- System starts only for authorized users
- Accurate face detection using OpenCV
- Fast response time
- Improved security compared to traditional systems

CONCLUSION.

The IoT-based smart vehicle start system using face detection provides a secure and efficient solution for vehicle ignition. It eliminates the need for physical keys and ensures that only authorized users can access the vehicle. The system is cost-effective, reliable, and suitable for modern smart vehicle applications.

FUTURE SCOPE.

The future scope of this project is:

- Integration with mobile application
- Cloud-based face database
- GPS tracking system
- AI-based improved recognition accuracy

ACKNOWLEDGMENT

We would sincerely like to thank our Guide Prof. Y. S. Ghodake for his valuable guidance, continuous encouragement, and constant support throughout the development of this project. We are also thankful to our Head of Department Dr. S. M. Lambe for his constant encouragement and support in this project. We also thank our Project Coordinator Prof. P. R. Kulkarni and Principal Dr. S. P. Patil for providing the necessary facilities.

REFERENCES

- [1] F. Schroff, D. Kalenichenko, and J. Philbin, "FaceNet: A unified embedding for face recognition and clustering," in Proc. IEEE Conf. Comput. Vis. Pattern Recognit. (CVPR), 2015, pp. 815–823.
- [2] A. G. Howard et al., "MobileNets: Efficient convolutional neural networks for mobile vision applications," arXiv preprint arXiv:1704.04861, 2017.
- [3] OpenCV Documentation, "Face Recognition using Local Binary Patterns (LBPH)," Online Tutorial, Available: <https://docs.opencv.org>. (Accessed: current year).
- [4] R. Patil, M. K. Sharma, and P. R. Singh, "Real-Time Face Recognition System using Raspberry Pi and OpenCV," Int. J. Comput. Appl., vol. 182, no. 27, 2019.
- [5] K. Jain and A. Kumar, "Embedded Face Recognition: Performance Evaluation on Low power Systems," in Proc. Int. Conf. Intelligent Systems and Embedded Computing, 2020.

Copyright & License:

© Authors retain the copyright of this article. This work is published under the Creative Commons Attribution 4.0 International License (CC BY 4.0), permitting unrestricted use, distribution, and reproduction in any medium, provided the original work is properly cited.