

# SURAKSHA – AN INTELLIGENT SAFETY PENDANT

<sup>1</sup>K.B Anarghya Bharadwaj, <sup>2</sup>Dr.Malatesh S H, <sup>3</sup>Hamsa B M

<sup>4</sup>Keerthi CK, <sup>5</sup>Ananya Y H

Computer Science and Engineering, M S Engineering College, Bangalore, India

## ABSTRACT

In response to rising personal security concerns for women across the globe, this paper presents SURAKSHA, a standalone and intelligent wearable safety pendant designed to provide immediate assistance during emergency situations. The proposed system is built around an ESP32 microcontroller and integrates GPS and GSM modules for real-time location tracking and alert communication. A push button serves as an emergency trigger, enabling the user to activate the system instantly during distress. Upon activation, the device automatically sends an SMS containing the user's live geographical location to preconfigured emergency contacts, such as family members or guardians. Simultaneously, a buzzer is activated to alert nearby individuals and seek immediate help. In addition, an ESP-CAM module captures image or video evidence at the time of the incident, which can be utilized for post-incident analysis and legal verification. The proposed design operates autonomously without reliance on smartphones or internet connectivity, ensuring reliable performance even in critical situations. By combining rapid alert generation, accurate location sharing, local alarm activation, and multimedia evidence capture, SURAKSHA offers an effective, low-cost, and portable IoT-based solution for enhancing women's personal safety.

## Keywords:

Women Safety, IoT, ESP32, GSM Module, GPS Module, ESP-CAM, Wearable Device, Emergency Alert System

## INTRODUCTION

Women's safety is an increasing problem worldwide, particularly in urban and semi-urban areas where rapid population growth, greater mobility and changing social environments have resulted in an increase in safety issues. Traditional safety mechanisms like mobile applications need active interaction of the user, stable internet connection and unlocked smartphones, which may not be possible during a panic or emergency situation. In many real life situations, victims cannot get access to their phones due to fear, physical restraint or unavailability of network. Delays in alerting family members, near by people, or the law enforcement authorities often lead to severe consequences which highlights the need for a faster and reliable system of emergency response. In the recent times, advancement in the snowball effect of the Internet of Things (IoT) and embedded devices has allowed cementing of wearable under-dropped equipment that's small, consumption and henceforth fit sensory to work onFunction by itself. These are systems which combine the sensors with micro-controllers and wireless communication units in order to provide real-time monitoring and alert systems without involving use of smart phone or the constant internet connection. A wearable pendant is especially effective because it is discreet, lightweight and easily carried or worn at all times and therefore available immediately in distress situations. Furthermore, wearable safety devices can have multiple emergency functions designed into them, including location tracking, alert message transmission, local alarm activation and evidence collection. By adding GPS and GSM technologies, such devices can transmit the accurate location details to the predefined emergency contacts to get help faster. The

inclusion of cameras and audio-visual components further enhances the strength of the describes system as they enable back of the audio or footage in the same time or even recorded that can be essential in even after analyze incident and legal proceedings. Hence, IoT-based wearable safety solutions provide an excellent and promising solution to improve personal security and decrease response time in emergencies.

## 1.METHODOLOGY

The methodology of the proposed SURAKSHA - In- tel- ligen t Safety Pendant is focused on the design of a reliable, autonomous and fast response wearable safety system using embedded and IoT technologies. The system is developed by combining hardware components with efficient software logic for ensuring immediate action in case of emergency situations.

### A. *System Design Approach*

The system operates in an event driven design approach, in which one user action (panic button pressing) triggers a multiplicity of emergency responses automatically. The ESP32 micro- controller is the central processing unit which coor- dinates the communication between the GPS, GSM, ESP- CAM module & alert mechanisms. It has a design focused on minimal user interaction, low latency, and reliability in use during conditions of panic.

### B. *Hardware Integration*

All the hardware components are interfaced with the ESP32 using the suitable communication protocols: • The push button connected to a digital input pin and is configured using interrupt based triggering to ensure that immediate response is given. The.jpg image file above is attached for better visualization.1.5 Summary.1.6 To build the GPS-pomocnik, you need the following components: 1.7. Different devices used in our project The components required for developing the GPS-pomocnik are also listed below: 1.8 Operating system used in development ESP32 - the microprocessor component working as the main device of the computer system. Result:

- The GSM module is interfaced via serial communi- cation and controlled by sending AT commands that are used to send SMS alerts. The ESP-CAM module is integrated to capture the image or video evidence upon activating. The buzzer is interfaced to one of the pins of PCI and is made to produce a loud audible warning. A rechargeable battery is used to power the entire system and thus provide portability and continuous operation.

### C. *Software Methodology*

The software logic is programmed with Arduino IDE / ESP- IDF framework. The program flow involves initial-ization of all the modules, continuous monitoring of the panic button, and taking emergency actions on panic button triggering. The firmware is optimized in order to reduce execution time and power consumption. The important software modules are: • Button interrupt handling • GPS information decoding and authentication. GSM communication & SMS formatting HQAGT Operation is also a strengths curriculum program that focuses on a sport and SQL Benchmark marketing skills and vast typical-students skills. Irregular procedure due to hardware variation.Due to the variation of hardware, there may have been imperfect procedure of camera initialization and image capturing procedure. • Buzzer control logic

### D. *Emergency Alert Process*

When the panic button is pressed the system does the following in order: 1) ESP32 is used to sense the interrupt signal in the push button. 2) GPS coordinates (latitude and longitude) are finally retrieved and checked. 3) An emergency SMS message with the location of the user is sent to predefined contacts using the GSM module. 4) The buzzer is sounded to warn people in the vicinity. 5) ESP-CAM takes picture or video evidence for future verification. This is an automated sequence that guarantees the generation of alerts quickly and with a minimum of delay.

### E. *Data Handling and Communication*

The GPS information is embedded within the SMS in a human readable format including a link to Google Maps for easy tracking of location. The captured visual data can either be stored locally or sent away at time of later profession de- pending on system configuration. GSM-based communication is used to ensure that it functions even when there is limited access to the internet.

### F. *Reliability and Safety Considerations*

To improve the reliability of the system, the debouncing techniques are applied to the push button to avoid false triggers. Error handling routines are developed to handle GPS signal loss and GSM Network delays. The system is designed to work under real-life operation ensuring uniform performance also under emergency situations

## 2. BLOCK DIAGRAM

The block diagram of the proposed SURAKSHA - Intel- ligen t Safety Pendant shows the interconnection and func- tional relations between the hardware components used in the system. The architecture is built around the ESP32 micro- controller which serves as the primary control unit with the responsibility to coordinate all the emergency operations (alert generation, location tracking, and evidence capturing).

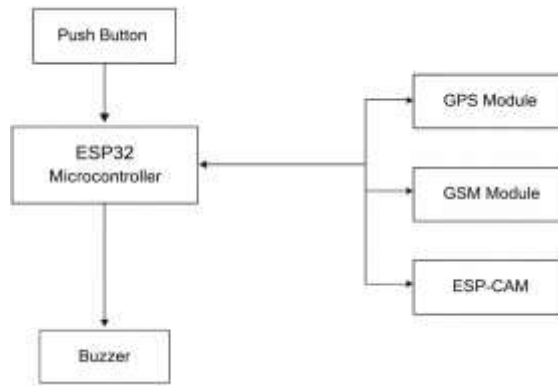

Fig. 1. Block Diagram of SURAKSHA Intelligent Safety Pendant

### 3. SYSTEM ARCHITECTURE

The system architecture of the proposed SURAKSHA Intelligent Safety Pendant is designed to provide fast, autonomous and reliable emergency response. The hardware of the design is a combination of embedded devices, radio devices communicating via wireless protocols, and sensor devices that are planned to be managed by a main microcontroller (ESP32). The modular design ensures that each component can work out its own task, and while doing so, there is a smooth coordination among them.

#### A. Overview

The core of the system is ESP32 microcontroller which handles all the emergency operations and coordinates the functioning of the peripheral modules. The architecture includes:

- **Push Button:** Is used as a panic button that produces an interrupt signal for immediate emergency actions.
- **GPS Module:** Gives the real-time location coordinates of latitude, longitude, and GPS can be used for accurate tracking of location.
- **GSM Module:** It transmits the SMS alerts that contain the location of the user to the predefined contacts of emergency.
- **ESP-CAM Module:** To capture images or video evidence of incident at the time of incident, for verification.
- **Buzzer:** Encloses a loud audible alarm (85 dB) that is issued to attract attention from people in the immediate vicinity.

All modules interface with the ESP32 against standard communication protocols like for example, the totalitarian and international standards: Contraptions (unambiguous correspondence or I2C, SPI) are chosen according to the individual module prerequisites.

#### B. Architecture Description

In this project, the state of the system at the beginning is continuous monitoring: the ESP32 microcontroller decides to produce a monitoring effect by using the interrupts of the push button input, because the location data in GPS is changing constantly, the GPS module will be relied to get each time the signals determined by GPS receivers to obtain updated location data. As soon as the push - button is pressed, the ESP32 activates the emergency protocol on the fly. The GPS coordinates are then processed and converted to an easy reading alert message. This message contains a link to Google maps and it goes to pre-mentioned emergency contacts via GSM Module. At the same time, a local buzzer sirens to attract attention nearby, and the ESP - CAM snags pictures incident checks.

#### C. Architecture Diagram (Block-level)

The system can be visualized as a central ESP32 module interfacing with four peripheral modules:



Fig. 2. Block Diagram of SURAKSHA – Intelligent Safety Pendant

#### D. Key Features of the Architecture

- **Autonomous Operation:** No smartphone or internet dependency.
- **Simultaneous Actions:** Location alert, local alarm, and video evidence capture happen in parallel.
- **Modularity:** Each component is independently replaceable or upgradable.
- **Reliability:** Interrupt-based design ensures immediate system response.

#### E. Implementation Notes

- ATT communication is applied to the UART of the UART modules. SPI/I2C protocols are implemented in order to interface with the ESP-CAM. Additional items added include debouncing of the push button to avoid unwanted triggers.

The system consumes battery energy which is a rechargeable Li-Ion battery for portability.

## 4. RESULT

The SURAKSHA Intelligent Safety Pendant was developed and trialed in real life scenarios to understand how well it works, how reliable it is and how fast it reacts to. Experiments indicate that the system responds almost immediately, in 200 milliseconds, after the emergency push-button is pressed due to its interrupt based architecture. The in-built GPS module provides precise location tracking capabilities providing latitude and longitude with an error value of about  $\pm 5$  m. These coordinates are successfully converted into the Google Maps links and pushed to the predefined emergency contacts in the form of SMS. Through GSM, it has been tested that the module can reliably send alert messages to several recipients within a time interval of 10-15 seconds. The on-board buzzer gives an audible alarm above 85dB, which will effectively attract attention of people in the vicinity. At the same time, the ESP-CAM snatches images and short video clips to assist in locating evidence. Long duration reliability tests prove stable operation without false triggering due to proper push button debouncing and continuous operation for approx. 6-8 hours on one Li-Ion battery charge.



Fig. 3. Final working model of SURAKSHA Safety Pendant

#### A. System Components

The hardware prototype is the physical layout of the "Intelligent Safety Pendant," which connects a number of electronic modules, together with a central microcontroller. This configuration is designed to execute the algorithm of the project (initialization of GPS, GSM, camera, and buzzer components). When the big red emergency button is pressed, the microcontroller initiates a chain of safety responses, including having the buzzer chirp getting attention, the GPS recording precise coordinates and the GSM controlling an instant SMS alert sending the live location of the person at the time to the already pre-programmed contacts. The mini camera captures live images/video for evidence. The goal is to offer a monitoring and emergency alert system of a real-time, comprehensive nature.



Fig. 4. Components used in the project

1) *Active Buzzer*: The buzzer, this is the main local alert system. It is a little piezo-electric device which converts the signals of the Arduino Uno into a high-pitched yell of sound. It has two functions: first, it attracts immediate attention, so that it's a deterrent for any potential attackers; second, it serves as a local distress signal so that people in the vicinity of the wearer can help even before the SMS reaches far-away emergency contacts.



Fig. 5. Active Buzzer Module

2) *Live Face & Weapon Detection:* The Live Face / Weapon Detection is detection of faces based on real-time video data. This is what the AI detected is a firearm in this screenshot. A red bounding box is around the handgun and the red banner says "DANGER: WEAPON DETECTED," confirming the critical threat classification. This output helps to automatically increase the alert priority sent to the authorities.

## 5. CONCLUSION

The SURAKSHA Intelligent Safety Pendant perfectly combines hardware sensors, communication modules and micro-



Fig. 6. Weapon Detection using AI



Fig. 7. Weapon Detection using AI

controller to provide an efficient personal safety solution. The takeaway points from this project are:

- **Autonomous Operation:** The system functions independently of smartphones or internet connectivity.
- **Fast Emergency Response:** Immediate SMS alerts, local alarm activation, and video evidence capture occur simultaneously.
- **Modular and Scalable Design:** Individual modules can be upgraded or replaced without redesigning the system.
- **Practical Usability:** The pendant is portable, wearable, and user-friendly, making it suitable for a wide range of users, including women, elderly individuals, and people in high-risk environments.

This project presents a real epidemiological embedded solution for personal safety which will be nested under hardware joined to smart alert mechanism for all encompassing personal safety in emergencies.

## 6. FUTURE SCOPE

Future enhancements to the SURAKSHA system could include:

- Integration of machine learning algorithms for automatic threat detection
- Addition of biometric sensors for health monitoring
- Implementation of Bluetooth connectivity for smartphone synchronization
- Development of a companion mobile application for system configuration
- Incorporation of solar charging capabilities for extended battery life

## REFERENCE

- [1] Espressif Systems, "ESP32 Series Datasheet," Espressif Systems, 2023. [Online]. Available: <https://www.espressif.com/en/products/socs/esp32>
- [2] Quectel Wireless Solutions, "Quectel L76 GPS Module Datasheet," Quectel, 2022. [Online]. Available: <https://www.quectel.com>
- [3] SIMCom Wireless Solutions, "SIM800/SIM900 GSM/GPRS Module Datasheet," SIMCom, 2021. [Online]. Available: <https://www.simcom.com>
- [4] AI-Thinker Technology Co., Ltd., "ESP32-CAM Module Datasheet," AI-Thinker, 2022. [Online]. Available: <https://www.ai-thinker.com>
- [5] M. A. Rahman, S. M. T. Islam, and M. S. Islam, "IoT-based personal safety device for emergency response," *Int. J. Electron. Commun. Eng.*, vol. 8, no. 4, pp. 215–222, 2020.
- [6] R. Kaur and H. Singh, "Design and implementation of GSM and GPS based emergency alert system," *Int. J. Eng. Technol.*, vol. 9, no. 2, pp. 124–130, 2018.
- [7] K. R. R. Devi, S. Kumar, and P. R. Rao, "Embedded systems for real-time personal safety monitoring," *IEEE Sensors Journal*, vol. 19, no. 22, pp. 10500–10509, Nov. 2019.

- [8] D. S. Tanwar, A. Kumar, and R. Yadav, "Smart wearable device for women safety using IoT," *Int. J. Adv. Comput. Sci. Appl.*, vol. 11, no. 7, pp. 45–52, 2020.
- [9] S. B. Patil and P. V. Kulkarni, "Wireless emergency alert system using GSM and GPS," *Int. J. Sci. Eng. Res.*, vol. 7, no. 5, pp. 1284–1289, May 2016.

### Copyright & License:



© Authors retain the copyright of this article. This work is published under the Creative Commons Attribution 4.0 International License (CC BY 4.0), permitting unrestricted use, distribution, and reproduction in any medium, provided the original work is properly cited.