

# REDUCING THE IMPACT AND OPERATING CONDITIONAL MECHANICAL VIBRATIONS ON HYDRAULIC VALVES: EXPERIMENTALLY AND THEORETICALLY

<sup>1</sup> **Bhoomika B Borade**

<sup>1</sup>M.E(Machine Design)

<sup>1</sup>Mechanical Engineering,

Dr.J.J.Magdum College of Engineering, Jaysingpur, 416 101

**ABSTRACT**— *Vibrational behavior of fluid power systems is a very important aspect regarding life-time of the components and especially noise problems within hydraulic circuits. Vibration emitting and noise generating elements in hydraulic systems are valves. The impact of mechanical vibrations on the environment, particularly on hydraulic valves is one major problem in industry. Two ways of reducing the impact of mechanical vibrations on the valve are proposed and a theoretical analysis, constituting the basis for selecting a material for an effective vibration isolator for the valve, is carried out.*

*The objective of this study is to minimize a vibration in hydraulic system especially in hydraulic valve using various isolators like rubber pads of different thickness, washer, damper etc. and analyses the system by using FFT analyzer and MATLAB software. MATLAB analysis is done to find the anti-vibrating materials which have minimum vibration at same force applied on it and have three forces different operating condition. Experimentation is done for to find anti-vibrating materials which have minimum vibration at same force applied on it by using FFT analyzer. Finally, comparing all the results which obtain by software analysis and experimentally selection of one appropriate anti-vibrating material is done.*

**KEYWORDS** — *HYDRAULIC VALVE, VIBRATION, ISOLATORS, MATLAB ANALYSIS, FFT ANALYZER, ANTI-VIBRATING MATERIAL*

## I. INTRODUCTION

Vibrational behavior of fluid power systems is a very important aspect regarding life-time of the components and especially noise problems within hydraulic circuits. Vibration emitting and noise generating elements in hydraulic systems are valves.

The impact of mechanical vibrations on the environment, particularly on hydraulic valves is one major problem in industry. Two ways of reducing the impact of mechanical vibrations on the valve are proposed and a theoretical analysis, constituting the basis for selecting a material for an effective vibration isolator for the valve, is carried out.

A running engineering machine is a source of mechanical vibrations with a wide spectrum of frequencies, including low frequencies. The vibrations act on the operator inside the machine, on all the machine subassemblies and subsystems and indirectly, on the surrounding environment. For the sake of the health of the machine's valves, it is essential to identify the mechanical vibrations to which they are subjected. Such vibrations often may disturb the operation of the entire hydraulic system of a mobile machine. A disturbance in the operation of such a system is reflected in a change in the pressure fluctuation spectrum. The disturbance may lead to deterioration in the accuracy of positioning the actuators, to uneven operation, shortening of the machine's life and sometimes to a higher level of low-frequency noise emitted. Low-frequency vibrations and noise have a particularly adverse effect on hydraulic valves and the human being. In hydraulic valves they may excite the vibration of their control elements (such as the slide and the head). This occurs when the frequency of the external mechanical vibrations is close to that of the free vibrations of the valve control element. In the case of a human being, the vibrations via the skin mechanoreceptors transmit specific information to the central nervous system, causing reflex reactions of the human body. The vibrations are accompanied by noise, also with low-frequency components. The noise is the subject of EU standard regulations. Hydraulic equipment producers, however, rather seldom specify the operating requirements concerning the resistance of their products (e.g. valves) to mechanical vibrations.

In the recent past there has been a significant increase in the use of hydraulics in our industries. The use of oil hydraulic system as a means of power transmission in modern machines evolved a few decades earlier in the western world. But its application in Indian industries is of comparatively recent choice and hence, there is great deal of urgency and importance to master the art of its application and maintenance. Hydraulic system are not extensively used in machine tools, material handling devices, transport and other mobile equipment, in aviation system, etc. At the movement there exists a big gap between the availability and requirement of trained manpower in this vital field of modern engineering in India. To bridge the gap, it is essential that our design and application engineering and maintenance personnel from the lowest to highest level are given extensive, on the job training so that operation efficiency of machineries using a hydraulic system as the prime source of power transmission can be maintained at an optimum level. Apart from fluid power system designer, a good maintenance and millwright mechanism should also have first-hand theoretical knowledge to enable him to tackle practical problems encountered during installation, operation and maintenance of hydraulic equipment.

The purpose of this test is to determine any mechanical weakness and/or degradation in the specified performance of specimens and to use this information, in conjunction with the relevant specification, to decide upon the acceptability of the specimens. In some cases, the test method may also be used to demonstrate the mechanical robustness of specimens and/or to study their dynamic behavior. Categorization of components can also be made on the basis of a selection from within the severities quoted in the test.

The objective of this study is to minimize a vibration in hydraulic system especially in hydraulic valve using various isolators like rubber pads of different thickness, washer, damper etc. and analyses the system by using FFT analyzer and MATLAB software.

## II. VIBRATING SYSTEM

HV is a vibrating system which vibrations should be reduces. The hydraulic valve is mount on one platform, on same platform electric motor which sucks the hydraulic oil is mounting. Therefore the vibration on hydraulic valve is due to two reasons first is due to vibration of electric motor it means when electric motor run or doing its operation vibration is produce due to this vibration hydraulic valve also vibrates. Second is due to vibration of hydraulic valve itself it means that when valve is in working due to change in pressure of flow of hydraulic fluid vibration is occur in hydraulic valve. Due to both vibration hydraulic valve is vibrate.



**Fig.1. Vibrating System**

Therefore, vibrating system consists:

- 1) Hydraulic valve
- 2) Hobbing machine
- 3) Electric motor which is mounting on same platform of HV

### **Direction Control Valve**

To carry out such directional movement to several cylinders, the hydraulic system uses several directional control valves. The valves are mostly actuated electrically through solenoids. These valves change the direction of the flow of the hydraulic oil to the various cylinders and the control is eccentrically done by the operator in the proper sequence. It consists of spool inside a cylinder which is mechanically or electrically controlled. The movement of the spool restricts or permits the flow, thus it controls the fluid flow.

We are use the directional control valve i.e. 4/2 solenoid operating DCV. Which have two operating position and four port. Its designation is – DSG-01-2B2-A240-N1-50

Its maximum pressure is 315 kcf/cm<sup>2</sup> and the operating temperature range is (-15<sup>0</sup>C to 60<sup>0</sup>C) i.e. temperature of oil use in valve.

Specifications of valve:

- Designation – DSG-01-2B2-A240-N1-50
- Maximum flow – 63 L\min
- Maximum operating pressure – 315 kcf/cm<sup>2</sup>
- Maximum T- line back pressure – 160 kcf/cm<sup>2</sup>
- Maximum changeover frequency – 300 cycle\min
- Mass – 2.2 kg



**Fig.2.Direction Control Valve**

### **Hobbing Machine**

Hobbing machine is do vertical broaching processes. Broaching is a machining operation in which the tool has a linear displacement. The tool shape is the same as the part shape and is well suited to producing complex cross sections. In broaching, each tooth progressively removes some material, to produce the final shape. All operations (roughing, semi-finishing, finishing) are achieved in a single pass. Specially recommended for large series, broaching is an alternative technology to milling, boring, turning, grinding and EDM. The broaching process is extremely accurate. The efficiency demonstrated in heavy production is unmatched by any other process. Broaching is especially suitable for automotive factories where high efficiency and a high level of accuracy is required. A surface broach is used to remove material from an external surface. Surface broaching is usually carried out on a vertical machine with a broach which is either pushed or pulled down. The entire length of the broach is usually fixed to the machine.

Hydraulic valve is providing hydraulic fluid to the hobbing machine. During the operation on hobbing machine pressure of HF is changes. By considering three conditions of operation (say starting, during and ending) pressure of HF is change and this change in pressure of HF is cause of vibration obtained in HV.

### **Electric Motor**

An electric motor is an electrical machine that converts electrical energy into mechanical energy. Most electric motors operate through the interaction between the motor's magnetic field and winding currents to generate force. Electric motors can be powered by direct current (DC) sources, such as from batteries, motor vehicles or rectifiers, or by alternating current (AC) sources, such as a power grid, inverters or generators.

Electric motors are one of the most commonly used pieces of equipment in industry. A basic electric motor has a magnetized stator that surrounds a rotor; the magnetic interaction between the two causes the rotor to spin. Faults in motors can develop due to resonances, imbalance, misalignment and foundation problems or improper mounting. These faults can lead to bearing failures and cause vibration.

### **III. ANTI-VIBRATING MATERIAL**

The common materials utilized for vibration isolation such as cork, felt, glass fiber, or elastomats, offer a wide choice to fit most requirements. The main differences between these materials are their stiffness, or natural frequency characteristics, and the amount of damping each can provide. However, the selection of the particular material is usually based on such non-vibration oriented requirements as resistance to chemicals, tear strength, abrasion resistance, cost, lateral stability, and load capacity. For example, natural rubber has good isolation. Characteristics and fair temperature dependent properties, but does not age well and does not have the resistance to chemicals possessed by some of the synthetics. Glass fiber which has been pre-stressed and compressed to high densities provides an effective vibration isolation system for floors of large buildings. Floating floor systems can be effective isolators, protecting sensitive instruments from building structural vibration, or preventing equipment vibrations from being transmitted to the building structure. Glass fiber pads are also used as unit isolators for machinery mountings. Cork pads, which consist of natural cork granules compressed and steam baked to form slabs of the desired density, have fine aging characteristics and are particularly suitable for isolating concrete foundations. Felt pads are used for applications in which an isolation material with good cementing characteristics is important. Felt has found widespread use in the textile machinery field and is generally recommended when machinery movement or rebound must be closely controlled.

#### **Isomat**

Isomat is a high quality, easy to use and economical elastomeric isolation material. It has low frequency vibration, acoustic and shock isolation. It is high quality chloro-prepen or neoprene compound.

#### **Features:**

- High resilience and low damping characteristics.
- Excellent shock absorption characteristics.
- Excellent ozone, oil and general chemical resistance.
- Low level of creep.
- Long lifetime.
- Fire / flame resistance.

#### **Synthetic Rubber**

It is a high performance general purpose anti vibration material used globally in a very wide range of industrial equipment and machine mounting applications as well as in buildings and structures.

#### **Features:**

- Reduces noise and vibration
- Excellent chemical resistance including oil, grease, cleansing agents
- Stable under a wide range of atmospheric conditions
- Low poisons ratio
- Ability to withstand very high dynamic and static loads
- Wide temperature range (-25<sup>0</sup>C to +120<sup>0</sup>C)
- Easy to cut into strips and pads

#### **Natural Rubber**

It is an 'environmentally friendly', high performance, durable and economical solution to provide vibration and impact sound insulation. It is produced from the highest quality recycled rubber and foam granulate with a polyurethane bonding agent in tightly controlled, state of the art manufacturing processes.

#### **Features:**

- 100% recycled and 100% recyclable
- Excellent impact sound insulation and vibration absorption
- Operating Loads up to 0.11N/mm<sup>2</sup> (110kPa)
- Simple and quick installation methods
- Excellent long-term resilience
- Resistance to moisture absorption and rot

#### **Washers**

Washers are used to isolate bolt-through connections by providing a resilient separation of the bolt and the isolated structure where there is no space available for an isolation sleeve.

**Features:**

- Used in conjunction with acoustic / anti-vibration pads to provide a degree of vibration isolation across bolt-through fixings where they are required for stability and security.
- They can be used in conjunction with other washers to increase acoustic performance by stacking together Manufactured for durability, performance and ease of onsite installation by vulcanising zinc plated washers to a Chloroprene (Neoprene) acoustic washer.
- Good oil, chemical and fire resistance.
- Operating temperature range from -10 to +90°C

**Selection of Anti-Vibration Materials**

Selection of anti-vibration materials is based on parameters like range of temperature, types of failure, chemical properties, cost of material etc. Comparison done between various materials as shown below:

Table No.1 comparison of AVM's

Sr. No.	Material	Chemical resistance	Temperature range (°C)	Failure	Avail-ability	Other properties
1	Isomat	Good	-30 to +120	Low creep rate (high age)	Medium	Shock absorber and flame resistance
2	Rubber	Ok	-30 to +80	Low age	High	Resistance to moisture absorption and recyclable
3	Cork	Good	-25 to +120	Creep rate 1.7	Low	.....
4	Washer	Good	-10 to +90	Deflection 0.4 to 1.0	High	Fire resistance

According to the comparison isomat is a good material, so we use isomat, synthetic rubber and washer as ant vibration materials. Availability of rubber is very high and its cost is comparatively lower than isomat, rubber materials are available in various size and shape and its properties like temperature range and failure age is suitable for valve. So rubber synthetic materials and isomat materials are selected.

**Selected AVM's***Nitrile Rubber*

Nitrile Rubber is synthetic rubber. It is high performance vibration and shock damping material. It has excellent chemical resistance property. It has high damping coefficient also deflation of material is less. Properties of AVM from catalogue is 1) damping coefficient = 0.09 2) dynamic frequency = 90 Hz 3) Deflection = 0.3 mm

*Rubber Re-inforced with cotton*

Rubber Re-inforced with cotton is synthetic rubber. It is neopropen compound which is moulded with cotton material. Properties of AVM from catalogue is 1) damping coefficient = 0.16 2) dynamic frequency = 300 Hz 3) Deflection = 0.04 mm

*Isomat*

Isomat is elastomeric material. It is high quality ISO6446 compliant chloroprene compound. It provides excellent low frequency vibration, acoustic and shock isolation. It has high damping coefficient also deflation of material is less. Properties of AVM from catalogue is 1) damping coefficient = 0.13 2) dynamic frequency = 22.5 Hz 3) Deflection = 0.75 mm

*Washer*

Material of washer is Chloroprene (Neoprene) compound, which is synthetic rubber. Properties of AVM from catalogue is 1) damping coefficient = 9.5 N-sec/mm 2) Deflection = 1.00 mm

This four AVM's are selected by comparing it's mechanical properties, availability and price's from above selecting categories; which categories are selected upon AVM's availability, there chemical properties like resistance, range of temperature, types of failure etc.

**IV. MATLAB SOFTWARE**

MATLAB is a high-performance language for technical computing. It integrates computation, visualization, and programming in an easy-to-use environment where problems and solutions are expressed in familiar mathematical notation. Typical uses include:

- Math and computation
- Algorithm development
- Modeling, simulation, and prototyping
- Data analysis, exploration, and visualization
- Scientific and engineering graphics
- Application development, including Graphical User Interface building

**Calculations for MATLAB analysis**

We known that basic mathematical equation for any vibratory system is

$$m\ddot{x} + c\dot{x} + kx = F \sin \omega t$$

So, Calculations for MATLAB is as follows –

**Stiffness and Damping Coefficient of AVM's**

To calculate theoretical value of stiffness (k) and damping coefficient (c) of anti-vibrating material

For Nitril Rubber (i.e. sample R<sub>2</sub> and R<sub>3</sub>):

I) Stiffness of rubber =>

$$k = \frac{\text{mass of system}}{\text{deflection in antivibating pad}} = \frac{m}{\Delta s}$$

We know the mass of system from eq.(2)

$$m = 169 \text{ N and } \Delta s = 0.3 \text{ mm (approx.)}$$

$$k = \frac{m}{\Delta s} = \frac{169}{0.3}$$

$$k = 563.33 \text{ N/mm}$$

II) Coefficient of rubber =>

$$c = \zeta \times 2m\omega_n$$

$$= \zeta \times 2m \times 2\pi f$$

from catalogue,

$$\zeta = 0.09$$

$$f_{\text{dynamic}} = 90 \text{ Hz}$$

So,

$$c = 2m \times 2\pi \times \zeta \times f$$

$$= 2 \times 169 \times 2\pi \times 0.09 \times 90$$

$$c = 17193.38 \text{ N-sec/mm}$$

For Rubber re-inforced with cotton (i.e. sample R<sub>1</sub>):

I) Stiffness of rubber =>

$$k = \frac{\text{mass of system}}{\text{deflection in antivibating pad}} = \frac{m}{\Delta s}$$

We know the mass of system from eq.(2)

$$m = 169 \text{ N and } \Delta s = 0.04 \text{ mm (approx.)}$$

$$k = \frac{m}{\Delta s} = \frac{169}{0.04}$$

$$k = 4225 \text{ N/mm}$$

II) Coefficient of rubber =>

$$c = \zeta \times 2m\omega_n$$

$$= \zeta \times 2m \times 2\pi f$$

from catalogue,

$$\zeta = 0.16$$

$$f_{\text{dynamic}} = 300 \text{ Hz}$$

So,

$$c = 2m \times 2\pi \times \zeta \times f$$

$$= 2 \times 169 \times 2\pi \times 0.16 \times 300$$

$$c = 17193.38 \text{ N-sec/mm}$$

For Isomatic material (i.e. sample E<sub>1</sub> and E<sub>2</sub>):

I) Stiffness of rubber =>

$$k = \frac{\text{mass of system}}{\text{deflection in antivibating pad}} = \frac{m}{\Delta s}$$

We know the mass of system from eq.(2)

$$m = 169 \text{ N and } \Delta s = 0.75 \text{ mm (approx.)}$$

$$k = \frac{m}{\Delta s} = \frac{169}{0.75}$$

$$k = 225.33 \text{ N/mm}$$

II) Coefficient of rubber =>

$$c = \zeta \times 2m\omega_n$$

$$= \zeta \times 2m \times 2\pi f$$

from catalogue,

$$\zeta = 0.13$$

$$f_{\text{dynamic}} = 22.5 \text{ Hz}$$

So,

$$c = 2m \times 2\pi \times \zeta \times f$$

$$= 2 \times 169 \times 2\pi \times 0.13 \times 22.5$$

$$c = 6.208 \text{ N-sec/mm}$$

For Washer material (i.e. sample  $W_1, W_2$  and  $W_3$ ):

I) Stiffness of rubber =>

$$k = \frac{\text{mass of system}}{\text{deflection in antivibating pad}} = \frac{m}{\Delta s}$$

We know the mass of system from eq.(2)

$$m = 169 \text{ N and } \Delta s = 1.00 \text{ mm (apprax.)}$$

$$k = \frac{m}{\Delta s} = \frac{169}{1.00}$$

$$k = 169 \text{ N/mm}$$

II) Coefficient of rubber =>

$$c = \zeta \times 2m\omega_n$$

$$= \zeta \times 2m \times 2\pi f$$

from catalogue,

$$c = 9.5 \text{ N-sec/mm}$$

### Mass of Vibrating System

Anti-vibrating pads are inserting below the hydraulic valve, so to calculate the force on the Anti-vibrating pads we have consider load/force on hydraulic valve which is cause of vibration of hydraulic valve. Hydraulic valve and the motor which provide hydraulic fluid to valve is mounting on same platform so, the vibration in hydraulic valve is due to vibration in motor. Also vibration due to resistance or flow of hydraulic fluid is negligible. Therefore the total mass of vibrating system is a mass of electric motor and the mass of hydraulic valve.

We have to calculate mass of system,

Power of Motor = 3 hp = 2238 watt

Speed of Motor = 1440 RPM

$$\text{power(in watt)} = \text{torque} \times \frac{2\pi \times \text{speed(in rpm)}}{60}$$

$$\therefore \text{torque} = \frac{\text{power} \times 60}{2\pi \times \text{speed}}$$

$$\therefore \text{torque} = \frac{2238 \times 60}{2\pi \times 1440}$$

$$\therefore \text{torque} = 14.84 \text{ N.m}$$

We know,  $\text{torque} = \text{force} \times 2\pi r$

Where,  $r$  =radius of armature of motor =14mm =14×10<sup>-3</sup>m

$$\therefore \text{force} = \frac{14.84}{2\pi \times 14 \times 10^{-3}} = 168.70 \text{ N}$$

$$168.70 \text{ N} = 17.2 \text{ kg}$$

.....(1kg = 9.81 N)

We known, the mass of hydraulic valve = 1.6 kg

$$\text{So, Total mass of vibrating system} = 17.2 + 1.6 \\ = 18.8 \text{ kg (i.e.184.5N)}$$

**Force (F) on AVM's**

Also find the force on anti-vibrating pad at various operating conditions. Change in force of hydraulic valve during operation is depending upon operating condition and specification of machine.

The machine is a hobbing machine; hobbing is a machines process for making gears, splines and sprockets on a hobbing machine, which is a special type of milling machine. The teeth or splines are progressively cut in to the work piece by series of cuts made by a cutting tool called a hob. Compare to the other gear forming process it is relatively in expensive but still quite accurate, thus it is used broad range of parts and quantities. It is most widely used gear cutting process for creating spur and helical gears and more gears are cut by hobbing than any other process since it is relatively quick and in expensive.

Details of machine are follows

Table No.2. Specifications of Hobbing machine and tool

1.	Cutting speed of tool	: 280 mm/min = 0.28 m/min
2.	Material of tool	: carbide
3.	Maximum length of work piece	: 80 mm
4.	Pitch	: 0.5 module
5.	No. of Teeth	: 43
6.	Rack angle	: 30 <sup>0</sup>
7.	Width of work piece	: 60 mm
8.	Diameter of work piece	: 40 mm
9.	Tensile strength of tool	: 344.8 MPa
10.	Material of work piece	: Mild Steel
11.	Rise per tooth	: 0.1
12.	Cutting depth/tooth	: 0.03
13.	Specific cutting resistance	: 3 kN/mm <sup>2</sup>

We knew the table of calculation:

Table No. 3. Calculations for cmti manual

1.	Cutting speed	v	m/min
2.	Maximum length of work piece	$l_{max}$	mm
3.	Pitch of broach teeth	p	mm
4.	No. of teeth cutting at a time	Z	$Z = \frac{l_{max}}{p} + 1$
5.	Rack angle	$\gamma$	Deg.
6.	Tensile strength of work piece	$\sigma$	Kgf/mm <sup>2</sup>
7.	Rise per tooth	Sz	mm
8.	Specific cutting force	Ks	Kgf/mm <sup>2</sup>
9.	Sum of length of all teeth engaged at any instant	L*	mm
10.	Cutting force	Pz	Kgf

- $Ks = 450 + 3\sigma - 11\gamma - 2500Sz$
- $L = \pi dz$
- $Pz = Ks.L.Sz$

To calculate cutting force of tool, from above table

$$1) Ks = 450 + 3\sigma - 11\gamma - 2500Sz$$

$$= 450 + 3 \times 344.8 - 11 \times 30 \times \frac{\pi}{360} - 2500 \times 0.1$$

$$= 1231.52 \text{ kgf/mm}^2$$

$$2) L = \pi dz$$

$$.z = \frac{80}{43} + 1 = 2.86$$

$$.L = \pi \times 40 \times 2.86 = 359.39\text{mm}$$

$$3) Pz = 1231.52 \times 359.39 \times 0.1 = 434.05 \text{ kN}$$

To calculate load on anti-vibrating pad

$$.Load = width \text{ of cut} \times cutting \text{ depth/tooth} \times no. \text{ of engaged cutting teeth} \times specific \text{ cutting resistance}$$

For, no. of engaged cutting teeth = 1

$$L_1 = 60 \times 0.03 \times 1 \times 3 = 5.4 \text{ kN}$$

For, no. of engaged cutting teeth = 20

$$L_2 = 60 \times 0.03 \times 20 \times 3 = 108 \text{ kN}$$

For, no. of engaged cutting teeth = 43

$$.L_3 = 60 \times 0.03 \times 43 \times 3 = 232.2 \text{ kN}$$

**MATLAB Analysis**

We have do MATLAB analysis to find the anti-vibrating material which have minimum vibration at same force applied on it. We have three forces at different operating condition; by applying that first we are found equations as below:-

We know the basic equation which is used in MATLAB

$$m\ddot{x} + c\dot{x} + kx = F \sin \omega t$$

$$\therefore \ddot{x} = \frac{1}{m} [-c\dot{x} - kx + F \sin \omega t]$$

**Equations in MATLAB**

For nitrile rubber:-

- a.  $184.5\ddot{x} + 17193.3\dot{x} + 563.33x = 5400 \sin \omega t$
- b.  $184.5\ddot{x} + 17193.3\dot{x} + 563.33x = 108000 \sin \omega t$
- c.  $184.5\ddot{x} + 17193.3\dot{x} + 563.33x = 232200 \sin \omega t$

For rainforced rubber:-

- a.  $184.5\ddot{x} + 101.8\dot{x} + 4225x = 5400 \sin \omega t$
- b.  $184.5\ddot{x} + 101.8\dot{x} + 4225x = 108000 \sin \omega t$
- c.  $184.5\ddot{x} + 101.8\dot{x} + 4225x = 232200 \sin \omega t$

For elastomer material:-

- a.  $184.5\ddot{x} + 6.21\dot{x} + 225.3x = 5400 \sin \omega t$
- b.  $184.5\ddot{x} + 6.21\dot{x} + 225.3x = 108000 \sin \omega t$
- c.  $184.5\ddot{x} + 6.21\dot{x} + 225.3x = 232200 \sin \omega t$

For washer:-

- a.  $184.5\ddot{x} + 9.5\dot{x} + 169x = 5400 \sin \omega t$
- b.  $184.5\ddot{x} + 9.5\dot{x} + 169x = 108000 \sin \omega t$
- c.  $184.5\ddot{x} + 9.5\dot{x} + 169x = 232200 \sin \omega t$

We have speed of system is 1440 rpm, so the frequency of system is

$$f = \frac{\omega}{2\pi}$$

$$\therefore f = \frac{1440}{2\pi}$$

$$= 229.183 \text{ Hz}$$

**Simulink model**

Simulink model for above equation is –

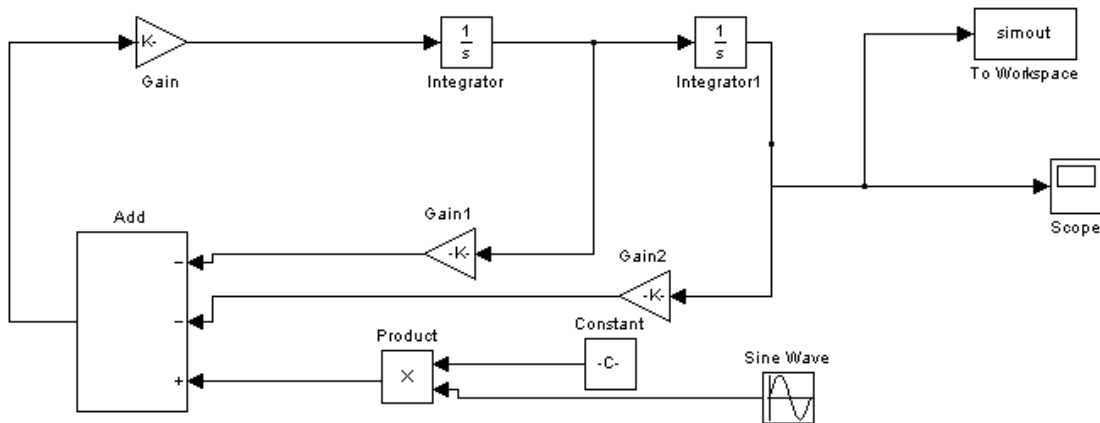

**Fig.3. Simulink model**



**Result of MATLAB analysis**

MATLAB analysis is done for four AVM and three force  $F_1= 5400$  N,  $F_2=108000$  N and  $F_3=232200$  N. Only peak to peak analysis of vibrational amplitude is done from above graphical results and then plot result table as follow.

Table No. 4  
Peak to peak analysis of vibrational amplitude

Force(in N) $\rightarrow$	5400	108000	232200
anti-vibrating material amplitude (in mm) $\downarrow$			
Nitrile rubber	0.0017	0.036	0.077
Rainforced rubber	0.025	0.50	1.05
Elastomer	0.12	2.25	5.00
Washer	0.13	2.50	5.5

From above result table we can conclude that two materials Nitrile rubber and Re-inforced rubber having minimum amplitude; so it should have minimum vibration. It means that it is good anti-vibrating material within all four materials. So theoretical and by doing MATLAB analysis we can conclude that the Nitrile rubber and Re-inforced rubber having high anti-vibration property.

**V. EXPERIMENTATION**

Objective of the experimental setup is to choose one appropriate anti-vibrating material from four anti-vibrating materials which is use to reduce vibrations in hydraulic valve. We already choose four anti-vibration materials on the basis of there properties and price, among those we have to select one best material.

Vibration occurs in the hydraulic valve is mainly due to vibration of the electric motor which is mount on same platform on which hydraulic valve is mount, so we have to reduce that vibration by using anti-vibrating material. Then we analyze the change in amplitude of vibration using FFT Analyzer. Details of experimental setup are as follow.

**Vibrating system**

Fig.4. Vibrating system

As shown in figure, the hydraulic valve is mount on one platform, on same platform electric motor which sucks the hydraulic oil is mounting. Therefore the vibration on hydraulic valve is due to two reasons first is due to vibration of electric motor it means when electric motor run or doing its operation vibration is produce due to this vibration hydraulic valve also vibrates. Second is due to vibration of hydraulic valve itself it means that when valve is in working due to change in pressure of flow of hydraulic fluid vibration is occur in hydraulic valve. Due to both vibration hydraulic valve is vibrate.

**Anti-vibrating Materials**

We are choosing four anti-vibrating materials which have different mechanical properties like stiffness and damping coefficient. R1 is the Re-inforced rubber with cotton material as shown in fig below



Fig. 5. AVM 1

R2 is the Nitril base rubber material as shown in fig below



**Fig.6. AVM 2**

E1 is elastomer material as shown in fig below



**Fig.7. AVM 3**

W1 is washers as shown in fig below



**Fig.8. AVM 4**

These are the different AVM of different properties and different size. It means that out of four AVM three are have same rectangular shape and same size (7x6cm) but washer has cylindrical shape.

### **Experimental Setup**

Direction control HV is regulated pressure and the direction of Hydraulic Fluid which is supply to the hobbing machine. This hydraulic fluid is use during the vertical broaching operation on hobbing machine, so pressure of HF is change during changing the condition of broaching operation. Mainly three operating condition was consider during the vertical broaching process. First is when job is mount on machine and the broaching tool just touch the job, it means just start the operation or first teeth of broaching tool are engaged with job. Second condition is during the broaching operation, means when middle part of vertical broaching is done. Third condition is when the operation is just ended or the last teeth of broaching tool are engaged with job. Therefore during these three conditions due to change in pressure of HF, so vibrational force is change and amplitude of vibration on HV also change.



**Fig.9. Experimental Setup  
(Vibrating system with Accelerometer and AVM)**

Hydraulic valve have vibrations; to measure that vibration with and without AVM using FFT Analyzer. FFT Analyzer is connected to the hydraulic valve by using accelerometer; which is transfer vibrational frequency to the FFT in form of electric charge which is equal to

the vibrational force. So get amplitude of vibration on the FFT. Then the four different type of AVM insert below the hydraulic valve one after another and take the reading for three different condition of vibrating force. The experimental setup is show fig. 7.8.

### Result of experimentation

Experimentally results of amplitude of vibration of hydraulic valve for particular condition of force and anti-vibrating material is show on FFT screen. From that result table for particular AVM is as shown below. It can be taken peak to peak analysis only i.e. peak-to-peak value of amplitude of vibration.

#### Result Table of Vibration of HV at no AVM

Table No.5. At No AVM	
HV Condition	Amplitude (in micro meter)
Starting operation	216
In middle of operation	205
Ending operation	198

#### Result Table of Vibration of HV at Nitrile Rubber as AVM

Table No.6. At Nitrile Rubber as AVM	
HV Condition	Amplitude (in micro meter)
Starting operation	92.1
In middle of operation	104
Ending operation	148

#### Result Table of Vibration of HV at Re-inforced with cotton Rubber as AVM

Table No.7. At Re-inforced with cotton Rubber as AVM	
HV Condition	Amplitude (in micro meter)
Starting operation	130
In middle of operation	148
Ending operation	153

#### Result Table of Vibration of HV at isomat as AVM

Table No.8. At isomat as AVM	
HV Condition	Amplitude (in micro meter)
Starting operation	153
In middle of operation	160
Ending operation	179

#### Result Table of Vibration of HV at washer as AVM

Table No.9. At washer as AVM	
HV Condition	Amplitude (in micro meter)
Starting operation	160
In middle of operation	167
Ending operation	191

### Conclusion

Results of No-AVM and various AVM should be compare for all condition, we get following result table:  
Table No.10. Comparison of results of No-AVM and various AVM for all condition

HV Condition	Various AVM amplitude in micro-meter				
	No-AVM	Nitrile Rubber	Rubber Re-inforced with cotton	Elastomer	Washer
Starting operation	216	92.1	130	153	160
In middle of operation	205	104	148	160	167
Ending operation	198	148	153	179	191

From above result table we can conclude that all four AVM has good AVM because its amplitude is less than amplitude of vibrational force at No-AVM but among all four AVM Nitrile rubber having minimum amplitude; so it should have minimum vibration. It means that it is good anti-vibrating material within all four materials. So experimentally found that Nitrile rubber is good anti-vibrating material; because its amplitude for all the condition of operation is less than another three materials. Therefore choose the Nitrile rubber as AVM for given vibrating system.

## VI. RESULT COMPARISON AND CONCLUSION

1) Following Table shows Comparison between all results obtained by MATLAB Analysis and experimentally taken through FFT Analyzer.

Table No.11. Comparison between results obtained by MATLAB Analysis and Experimentally taken

HV Condition	Various AVM amplitude in micro-meter									
	No-AVM		Nitrile Rubber		Rubber Re-inforced with cotton		Elastomer		Washer	
	MAT-LAB analysis	Exp. result	MAT-LAB analysis	Exp. result	MAT-LAB analysis	Exp. result	MAT-LAB analysis	Exp. result	MAT-LAB analysis	Exp. result
Starting operation	0	216	1.7	92.1	2.5	130	120	153	130	160
In middle of operation	0	205	36	104	500	148	2250	160	2500	167
Ending operation	0	198	77	148	1050	153	5000	179	5500	191

2) From above table we conclude that,

a) As vibrational force on AVM increase it increase amplitude of vibration. Therefore, deflection of AVM also increases. Therefore, we are say that, amplitude of vibration is low AVM has low deflection and good AVM is that which has low amplitude of vibration.

b) All four material are good anti-vibrating materials, its value of deflection is lower than no-AVM is use.

c) Two AVM has low deflation namely, Nitrile Rubber and Rubber Re-inforced with cotton. Form MATLAB analysis result, deflection of Nitrile Rubber is minimum among other materials. Experimentally results also show deflection of Nitrile Rubber is minimum than other materials.

d) The value of amplitude of vibration for Nitrile Rubber is minimum theoretically i.e. MATLAB Analysis as well as experimentally among four AVM. Also it is economically cheap material. Also have chemical resistance property so; it couldn't react with hydraulic valve in case of leakage. Therefore, Nitrile Rubber is select as a AVM for our Hydraulic valve to reduce vibration.

## VII. ACKNOWLEDGMENT

We would like to express our deep and sincere gratitude to my Guide Mr.M.V.Kharade, Department of Mechanical Engineering, for guiding us to accomplish this project work. It was our privilege and pleasure to work under his able guidance. We are indeed grateful to him for providing helpful suggestion; from time to time. We express our deep gratitude to Mr.P.R.Patil Head of Mechanical Engineering Department, for his valuable guidance and constant encouragement. We are very much thankful to Dr.S.H.Sawant, Principal, Dr. J.J. Magdum College of engineering, Jaysingpur for providing all the necessary facilities to carry out project work. Last but not least we are thankful to our parents for their moral as well as financial support.

## VIII. REFERANCE

- [1]M. Stosiak ,“Ways of reducing the impact of mechanical vibrations on hydraulic valves”.ACME-240; No. of Pages 9, 2014
- [2] H. Ortwiget et al, Experimental and analytical vibration analysis in fluid power systems, International Journal of Solids and Structures 42 (2005) 5821–5830.
- [3] N. Chenxiao, Z. Xushe et al, Study on vibration and noise for the hydraulic system of hydraulic hoist, in: Proceedings of 2012 International Conference on Mechanical Engineering and Material Science (MEMS), 2012.
- [4] Mr. Madhukar et al, ‘Experimental investigation of reducing vibration of hydraulic surface grinding machine while reversing the table which deals with Hydraulic Surface Grinding Machine used for fine surface finishing of job’. 2017 IJNRD | Volume 2, Issue 6 June 2017
- [5] PN-EN 60068-2-6:2008, Environmental research – part 2–6: tests – Fe test: vibration.
- [6] S. Chabane et al. Vibration and chattering of conventional safety relief valve under built up back pressure. 3rd IAHR International Meeting of the Workgroup on Cavitation and Dynamic Problems in Hydraulic Machinery and Systems, October 14-16, 2009, Brno, Czech Republic

- [7] Baoquan Kou et al. Electromagnetic and Mechanical Characteristics Analysis of a Flat-Type Vertical-Gap Passive Magnetic Levitation Vibration Isolator Hindawi Publishing Corporation Shock and Vibration Volume 2016, Article ID 5327207
- [8] Zebin Yang et al. Rotor Mass Eccentricity Vibration Compensation Control in Bearing less Induction Motor, Hindawi Publishing Corporation, Advance In Mechanical Engineering, Accepted 10 November 2014
- [9] Daniela Oanea Fediuc et al. compression modulus of elastomers, BULETINUL INSTITUTULUI POLITEHNIC DIN IAȘI Publicat de Universitatea Tehnică "Gheorghe Asachi" din Iași Tomul LIX (LXIII), Fasc. 2, 2013 Secția CONSTRUCȚII. ARHITECTURĂ Accepted for publication: may 2013
- [10] Shuichi Yabana et al. Mechanical Properties of Laminated Rubber Bearings for Three-Dimensional Seismic Isolation, Central Research Institute of Electric Power Industry, 1646, Abiko, Abiko-shi, Chiba-ken, 270-1194, JAPAN, 12 WCEE 2000
- [11] Elastomeric Materials book by Tampere University of Technology, The Laboratory of Plastics and Elastomer Technology, Kalle Hanhi, Minna Poikelispää, Hanna-Mari Tirilä
- [12] Appendix: Typical material property values useful in modeling mechanical, acoustic, and hydraulic elements, *System Dynamics: Modeling, Simulation, and Control of Mechatronic Systems, Fifth Edition*, Dean C. Karnopp, Donald L. Margolis and Ronald C. Rosenberg Copyright © 2012 John Wiley & Sons, Inc.
- [13] V. Mallikarjuna et al. Modification of Hydraulic Circuit of H-400 Gear Hobbing Machine, International Journal of Engineering Technology Science and Research (IJETSR), ISSN 2394 – 3386 Volume 3, Issue 2 February 2016
- [14] M. Stosiak, Vibration insulation of hydraulic system control components, Archives of Civil and Mechanical Engineering 11 (1) (2011) 237–248.
- [15] Experimental investigation of reducing vibration of hydraulic surface grinding machine while reversing the table, Mr. Madhukar M. Sirsikar, Prof. Hemant G. Patil, 2017 IJNRD Volume 2, Issue 6 June 2017
- [16] The Hobbing Machines LC 600-2000 LIEBHERR
- [17] ISOMAT IM BR (Nitrile) Anti-vibration FD IM BR 01-07 P1
- [18] NBR Anti vibration NBR 01-08
- [19] FARRAT Engineering Excellence Data Sheet AWR Acoustic Washer
- [20] WEG – Specifications of Electric Motors
- [21] Vibration Motor – Application Note, Yangyi Chen, April 4th, 2013

