

DESIGN AND ANALYSIS OF SPIRAL BEVEL GEAR WITH MINIMIZED WEIGHT

¹Nitin Chaudhari, ²Dr.D.N.Kamble

¹PG Student, ² Professor, Mechanical Department, Sinhgad Academy of Engineering, Pune, India

Abstract: This paper the spiral bevel gear (SBG) is a key component of the power transmission of intersection axes. Considering example as wood working machines, these are used to cut the wood work-piece for the purpose of making furniture, Casting pattern, wooden seat design, wood prototyping etc. In that machine a set of spiral bevel gears used for power transmission from motor to tool. The hand held tools weight and continues vibrations makes it difficult to operate the machine for longer time and also power consumption per unit cut has been very high, and vibrations lead to inaccuracy in cutting and error in profile shape. Thus methodology used in study is to carry out test on three sets of bevel plain gears (i.e. no weight reduction), secondly weight reduction done by providing recess on the gear face, an thirdly by providing equispaced holes on the face. Comparative the performance analysis of the gears by load so as to derive the optimal performance of the gears. The optimization of spiral bevel gear we can reduce weight, material, process timing and cost of production.

Keywords— Weight reduction, Face recess, Face holes, optimal performance characteristic

1. INTRODUCTION

The spiral bevel gear (SBG), with its high contact ratio, high strength and smooth driving, is widely used to transmit dynamic power in various mechanical products, including vehicles, mining machinery, aerospace engineering, and helicopters [1] to [4].

Generally gears are used for power transmission in most types of machinery and vehicles. The Bevel gears are mostly used because of their suitability for transferring power between nonparallel shafts at any speed or angle. Spiral bevel gears teeth have curved and sloped in relation to the pitch cone surface. As a result, an oblique surface is formed during gear mesh its allows contact to begin at one end of the tooth (toe) and smoothly progress to the other end of the tooth (heel). The gear design is highly complicated involving to satisfy the many constraints such as strength, pitting resistance, bending stress, scoring wear, and interference in involutes gears etc. 3-D model of set-up by using Unigraphics Nx-8.0, CAE of critical component and meshing using Ansys.ie the pre-processing part. Mechanical design validation using ANSYS. The critical components of the system will be design and validate by validation of strength calculations of critical for both modal and strength analysis. Optimization of the recess groove dimensions and whole sizes for minimize the weight and optimal strength.

2. METHODOLOGY

A. Topology optimization

Topology optimization of continuum structures is most challenging technically and rewarding economically. Rather than limiting the changes in the sizes of structural components, topology optimization provides much more freedom and allows to designer to create totally novel and highly efficient conceptual design for continuum structures. The stress level in all part of a structure can be determined by using a finite element analysis. The reliable indicator of inefficient use of material is low values of stress (or strain) in some parts of the structure. Ideally the stress in all part of the structure should be close to the same or safe level. This concept leads to the rejection criterion based on local stress. Where the low-stressed material is assumed to be under-utilized and is therefore eliminated subsequently. The removal of material can be conveniently undertaken by removing elements from the finite element model.

Topology optimization method has been used to optimize the structure of the gear. The minimum volume was set as the direct optimization goal. The topology optimization can provide designers with a conceptual design at the initial stage of a structural design, thus it improve the design efficiency, design quality, and reduce the development costs.

B. Problem Statement

The weight of the hand held tools and subsequent vibrations makes it difficult to operate the machine for longer time and also high power consumption, and vibrations lead to in accuracy in profile cutting and error in shape.

Thus it required study is to carry out test on three sets of bevel gears namely plain (i.e. no weight reduction), secondly weight reduction done by providing recess on the face of gear, an thirdly by providing even number and equi-spaced holes on the face.

C. Objective

Effect of weight reduction on vibration of gear through analysis.

3. DESIGN AND ANALYSIS OF SPIRAL BEVEL GEAR

A) Spiral bevel gear: plain

By considering plain bevel gear without any weight reduction. Geometry of gear as shown below.

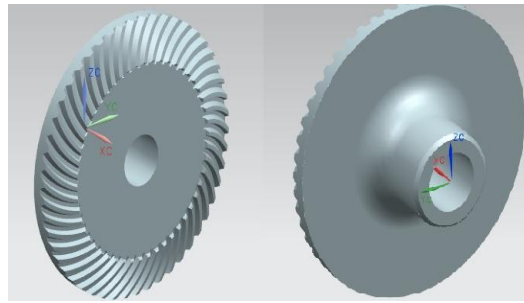

Fig.1 3D model of plain spiral bevel gear

1) Gear Specifications:

- No. Of Teeth = 50
- Pressure angle = 20 0
- Ration $m_G = N_g/N_p = 50 / 18 = 2.78$
- Shaft angle = 90 0
- Gear Pitch angle = 19.8 0
- Diametral pitch = 2.3 mm
- Face width = 13mm

2) Measurement Mass Properties

- Displayed Mass Property Values
- Volume = 33973.292562912 mm³
- Area = 13530.367141434 mm²
- Mass = 0.266032624 kg
- Weight = 2.608891183 N
- Radius of Gyration = 24.020538835 mm

3) Design torque = 0.29 x 2.78 = 0.81 N-m.

B) Result & discussion

Bevel Gear type	Mass of Gear Kg	Percent age Weight reduction	Maximum stress N/mm ²	Maximum deformation Mm
Plain	0.2660326	-	11.27	2.82 x 10 ⁻⁷
Hole reduction	0.23696	11.5	10.71	3.1810 ⁻⁷

4. ANALYSIS OF SPIRAL BEVEL GEAR –PLAIN

I. Geometry:

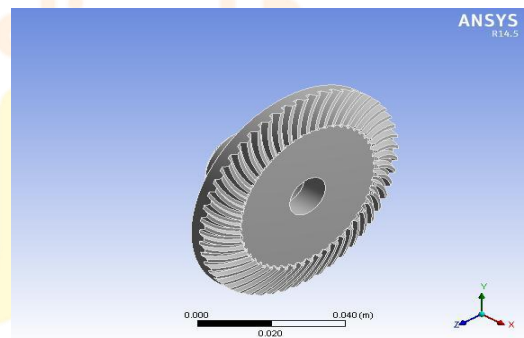

Fig.2 Geometry of spiral bevel gear

II. after Meshing

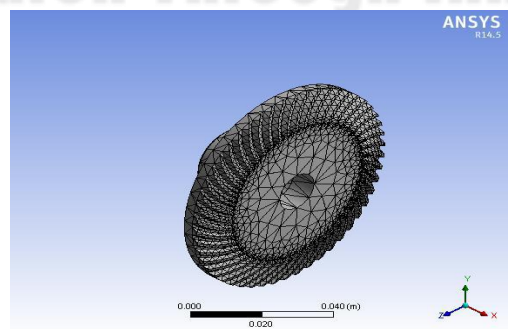

Fig.3 After Meshing

III. Boundary condition:

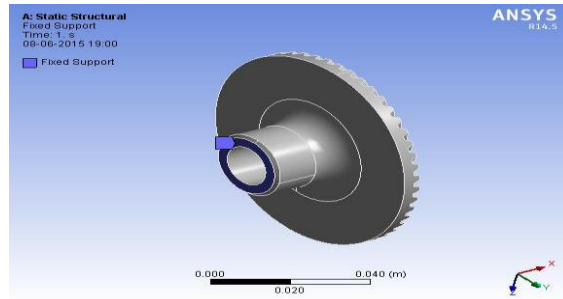

Fig.4 Applying Boundary condition

IV. Loading

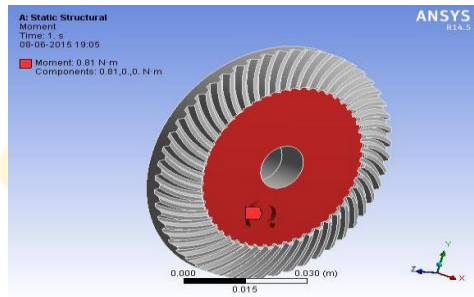

Fig.5 Applying Load

V. Results:

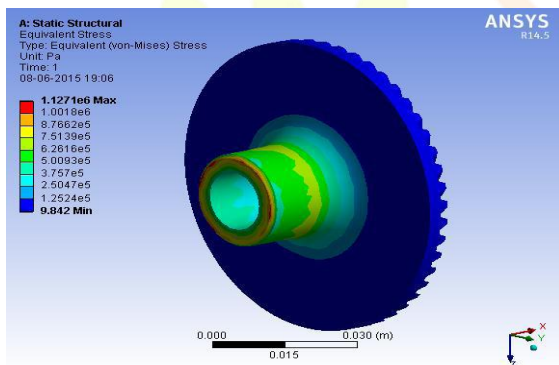

Fig.6 Static structural Equivalent stress

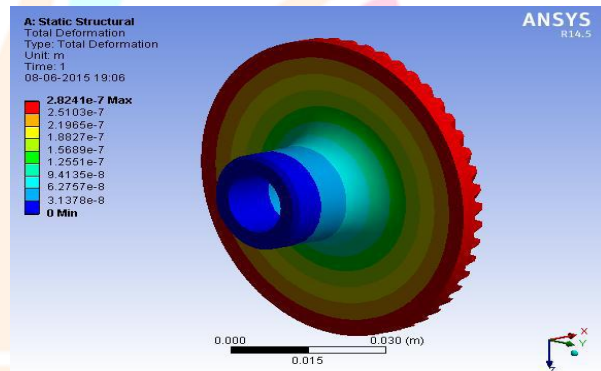

Fig.7 Static structural total deformation.

1. Maximum stress induced in the gear is $11.271 \text{ N/mm}^2 < \text{Allowable stress } 108 \text{ N/mm}^2$ the gear is safe .
2. Maximum deformation is $2.82 \times 10^{-7} \text{ mm}$

5. SPIRAL BEVEL GEAR: HOLE

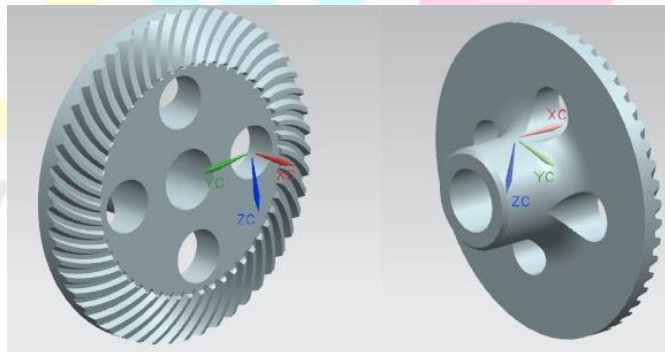

Fig 8 Spiral bevel gear: hole

1) Gear Data:

- No. Of Teeth = 50
- Pressure angle = 20 0
- Ration $mG = N_g/N_p = 50 / 18 = 2.78$
- Shaft angle = 90 0
- Gear Pitch angle = 19.8 0
- Diametral pitch = 2.3 mm

Face width = 13mm

2) Measurement Mass Properties

Displayed Mass Property Values

Volume = 30261.187506049 mm³

Area = 13879.209484242 mm²

Mass = 0.236964465 kg

Weight = 2.323829671 N

Radius of Gyration = 24.614748843 mm

Weight reduction = 11.5 %

B) Analysis of bevel gear-hole

I. Geometry

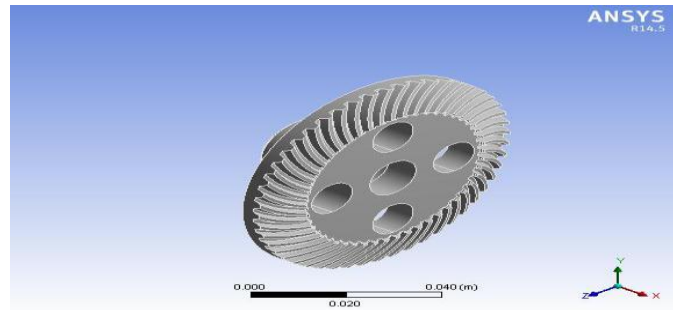

Fig.9 Geometry of spiral bevel

II. Meshing

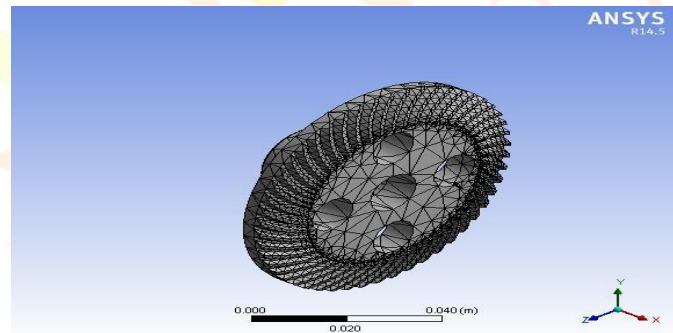

Fig.10 After Meshing.

III. Boundary condition:

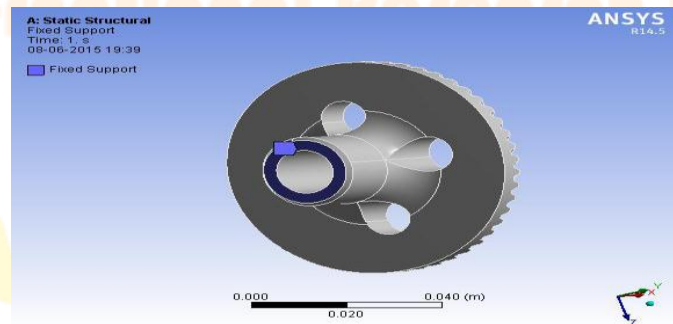

Fig.11 Applying Boundary condition

IV. Loading:

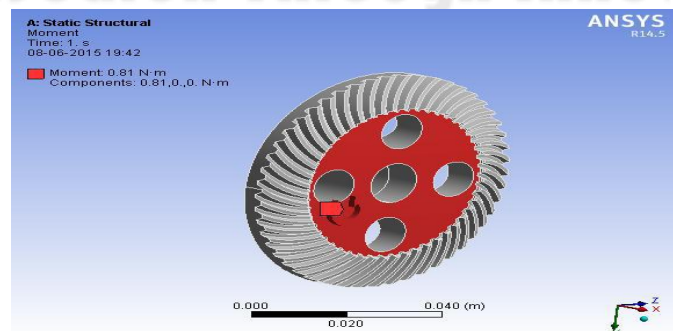

Fig.12 Applying Load

V. Results:

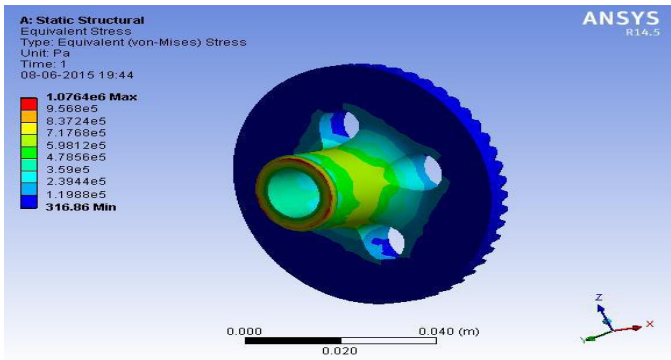

Fig.13 Static structural Equivalent stress.

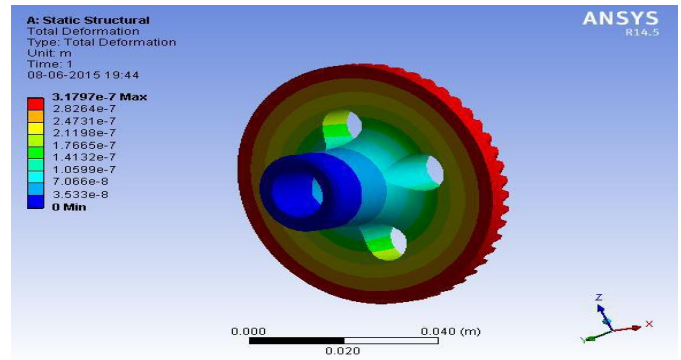

Fig.14 Static structural total deformation.

1. Maximum stress induced in the gear is $10.71 \text{ N/mm}^2 < \text{allowable stress } 108 \text{ N/mm}^2$ the gear is Safe.
2. Maximum deformation is $3.18 \times 10^{-7} \text{ mm}$

6. Test And Trial

A. On plain spiral bevel gear

Result table for theoretical displacement and acceleration

Sr. no	Load (kg)	Theoretical		Experimental	
		Displacement (mm)	Acceleration (m/sec ²)	Displacement (mm)	Acceleration (m/sec ²)
1	1.5	0.30958	1.47	0.31	1.6
2	1.8	0.37150	1.835	0.39	1.9
3	2.0	0.41277	2.034	0.44	2.24
4	2.3	0.47469	2.315	0.49	2.46
5	2.5	0.51597	2.56	0.53	2.69

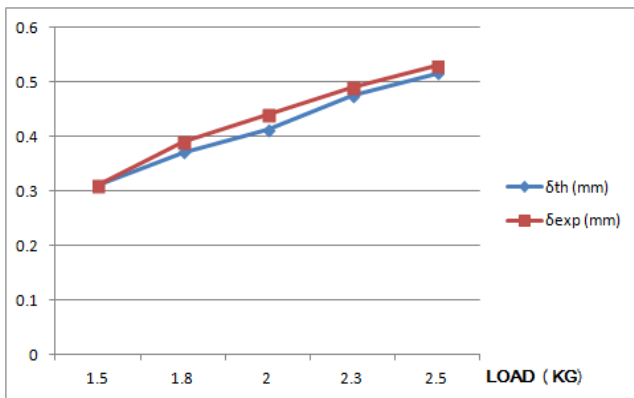

Graph 1. Load vs. Displacement

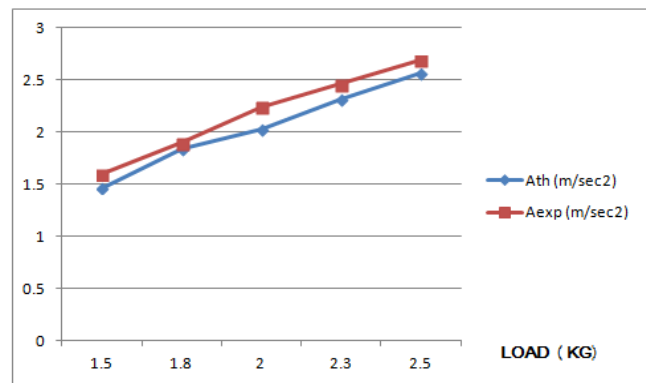

Graph 2. Load vs Acceleration

B. On plain spiral bevel gear –with hole reduction

Result table for theoretical displacement and acceleration:

Sr. no	Load (kg)	Theoretical		Experimental	
		Displacement (mm)	Acceleration (m/sec ²)	Displacement (mm)	Acceleration (m/sec ²)
1	1.5	0.30958	1.47	0.34	1.85
2	1.8	0.37150	1.83	0.41	2.25
3	2.0	0.41277	2.03	0.46	2.43
4	2.3	0.47469	2.31	0.51	2.79
5	2.5	0.51597	2.56	0.59	3.02

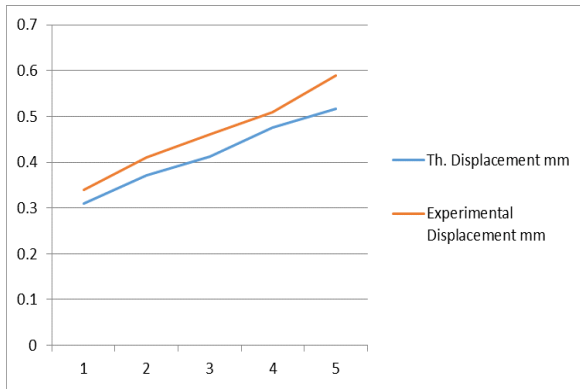

Graph 3 Load vs Displacement

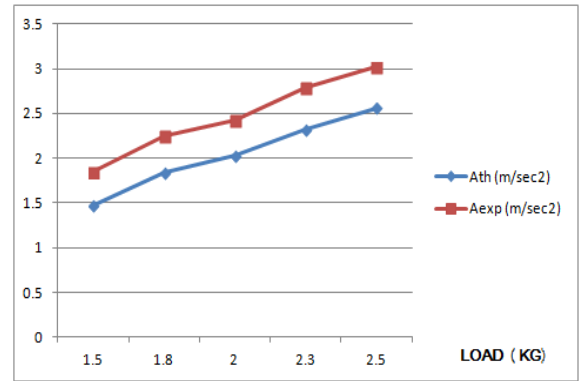

Graph 4 Load vs Acceleration

C. On spiral bevel gear –with face counter reduction Result table for theoretical displacement and acceleration

Sr. no	Load(kg)	Theoretical		Experimental	
		Displacement (mm)	Acceleration (m/sec ²)	Displacement (mm)	Acceleration (m/sec ²)
1	1.5	0.30958	1.47	0.347	1.95
2	1.8	0.37150	1.83	0.44	2.45
3	2.0	0.41277	2.03	0.49	2.63
4	2.3	0.47469	2.31	0.59	2.94
5	2.5	0.51597	2.56	0.63	3.22

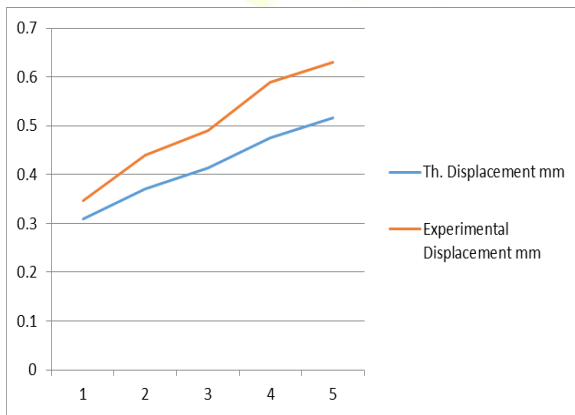

Graph 5. Load vs Displacement Graph

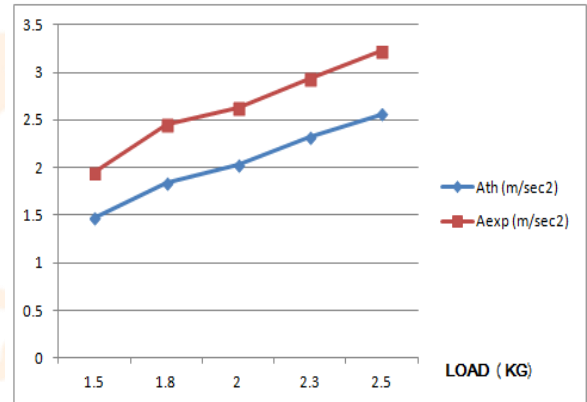

Graph 6 Load vs Acceleration

7. CONCLUSION

Development process able to design in an automated way the shape of spiral bevel gear flanks has been presented. It leads to a significant reduction of the development time, while allowing a strengthening of the quality of contact patterns by the reduction of the contact pressure. Its extension to the minimization of tooth contact errors seems possible, in order to contribute to the reduction of noise and vibration levels and therefore a higher durability of helicopter gearboxes.

Maximum weight reduction is achieved by hole education 11.5 %. Minimum stress is observed in case of Bevel gear as hole reduction. Maximum stress in all conditions is well below the allowable limit hence weight reduction by hole methods is recommended.

ACKNOWLEDGMENT

My profound thanks to my guide Dr. D. N. kamble sir, I am thankful to Prof. Dr. S. S. Kore sir Head of Department of Mechanical Engineering for his invaluable advice and constant encouragement to complete this Paper in a successful manner.

I am thankful to our ME coordinator Prof. S R Patil sir for his kind support and providing all facilities and academic environment for my Research paper work.

REFERENCES

- [1] Sekercioglu, T., Kovan, V. (2007). Pitting failure of truck spiral bevel gear. Engineering Failure Analysis, vol. 14, no. 4, p. 614-619, DOI:10.1016/j.engfailanal.2006.03.002.
- [2] .Polubinski, J., Ali, A. (2010). Simulation analysis of commercial truck spiral bevel gear process. International Journal of Modelling in Operations Management, vol. 1, no. 2, p. 179-208, DOI:10.1504/IJMOM.2010.038149.
- [3] Lewicki, D.G., Handschuh, R.F., Henry, Z.S., Litvin, F.L. (1994). Low-noise, High-strength, spiral bevel gears for helicopter transmissions. Journal of Propulsion and Power, vol. 10, no. 3, p. 356-361, DOI:10.2514/3.23764.

- [4] Handschuh, R.F., Bibel, G.D. (1999). Experimental and analytical study of aerospace spiral bevel gear tooth fillet stresses. Journal of Mechanical Design, vol. 121, no. 4, p. 565-572, DOI:10.1115/1.2829500.
- [5] Fong, Z.H., Tsay, B.C.B. (1991). A study on the tooth geometry and cutting machine mechanisms of spiral bevel gears. Journal of Mechanical Design, vol. 113, no. 3, p. 346-351, DOI:10.1115/1.2912788.
- [6] Xing, Y., Qin, S.F., Wang, T.Y., Cheng, K. (2011). Subdivision surface modeling for spiral bevel gear manufacturing. International Journal of Advanced Manufacturing Technology, vol. 53, no. 1-4, p. 63-70, DOI:10.1007/s00170-010-2813-1.
- [7] Ramgir M.S., "Achieving mass reduction in the spur gear using topology optimization for design evaluation and analysis" International Journal of Scientific Research and Management Studies, ISSN: 23493771 Volume 1 Issue 8, pg: 270-274.(2012).
- [8] Márk Ielkes, Daniel play and János marialigeti, "cutting parameters definition for kinematic optimization of spiral bevel gears," periodica polytechnica ser.transp.Eng. VOL. 30, NO. 1-2, PP. 93-109 (2010).
- [9] Fritz Klockea, Markus Brumma, "Influence of Gear Design on Tool Load in Bevel Gear Cutting", sciencedirect, Procedia CIRP 166 – 71(2012)

