

IJNRD | editor@ijnrd.org

WWW.IJNRD.ORG

# INTERNATIONAL JOURNAL OF NOVEL RESEARCH AND DEVELOPMENT

International Peer Reviewed & Refereed Journals, Open  
Access Journal | ISSN: 2456-4184

Scholarly Open access journals, Peer-reviewed, and Refereed  
Journals, Impact factor 8.76 (Calculate by google scholar and  
Semantic Scholar | AI-Powered Research Tool),  
Multidisciplinary, Monthly, Indexing in all major database &  
Metadata, Citation Generator, Digital Object Identifier(DOI),  
Monthly, Multidisciplinary and Multilanguage (Regional  
language supported)

Publisher and Managed by: IJPUBLICATION

**Impact factor: 8.76 | ESTD Year: 2016**



Website: [www.ijnrd.org](http://www.ijnrd.org) | Email: [editor@ijnrd.org](mailto:editor@ijnrd.org)

# INTERNATIONAL JOURNAL OF NOVEL RESEARCH AND DEVELOPMENT

(ISSN: 2456-4184)

International Peer Reviewed & Refereed Journals, Open Access Journal

Impact factor: 8.76 | ESTD Year: 2016

This work is subjected to be copyright. All rights are reserved whether the whole or part of the material is concerned, specifically the rights of translation, reprinting, re-use of illusions, recitation, broadcasting, reproduction on microfilms or in any other way, and storage in data banks. Duplication of this publication of parts thereof is permitted only under the provision of the copyright law, in its current version, and permission of use must always be obtained from IJNRD www.ijnrd.org Publishers.

INTERNATIONAL JOURNAL OF NOVEL RESEARCH AND DEVELOPMENT is published under the name of IJNRD Publication and URL: www.ijnrd.org



© IJNRD Journal

Published in India

Typesetting: Camera-ready by author, data conversation  
by IJNRD Publishing Services – IJNRD Journal.

IJNRD Journal, WWW.IJNRD.ORG

INTERNATIONAL JOURNAL OF NOVEL RESEARCH AND DEVELOPMENT  
ISSN NO: 2456-4184 | ESTD YEAR: 2016

**IJNRD**

IMPACT FACTOR: 8.76 BY GOOGLE SCHOLAR

Scholarly open access journals,  
Peer-reviewed, and Refereed  
Journals, Impact factor 8.76  
(Calculate by google scholar  
and Semantic Scholar |  
AI-Powered Research Tool) ,  
Multidisciplinary, Monthly,  
Indexing in all major database  
& Metadata, Citation Generator,  
Digital Object Identifier(DOI)

**CALL FOR PAPER**  
Paper Submission Till:  
29<sup>th</sup> of Current Month  
Submit Your Paper online @  
[www.ijnrd.org](http://www.ijnrd.org)

**Benefits of Publishing Paper in IJNRD**  
- Quick and Speedy Review and Publication Process.  
- A digital object identifier (DOI) and Hard-Soft Copy of Certificate.  
- Email and SMS Support to Author.  
- Fully Automated Process and Received Notification  
- Highly Secured SSL Based website and Author Panel.  
- Prestigious Reviewers from Well-known Institutes Universities among the world.  
- Provide author research guidelines & support by mail, SMS and the call.  
- Indexing of paper in all major online journal databases like Google Scholar, Thomson Reuters, Mandelley, Academia.edu, arXiv.org, Research Gate, CiteSeerX, DOAJ, DRJI, DocStoc, GetCited,Base,ISEDN, Wiki CFP, Index Copernicus Open J Gate, ISSUU, Scribd.

**EDITOR@IJNRD.ORG**  
**MO : 9429458311**  
**WWW.IJNRD.ORG**

Contact us For bulk paper Publications and Conference @  
[editor@ijnrd.org](mailto:editor@ijnrd.org)

Major Indexing

ISSN INTERNATIONAL STANDARD SERIAL NUMBER  
ResearchGate  
RESEARCHERID  
CiteSeerX  
SSRN  
Google Scholar  
Academia.edu  
arXiv.org

ISSN (Online): 2456-4184

INTERNATIONAL JOURNAL OF NOVEL RESEARCH AND DEVELOPMENT

(IJNRD) is published in online form over Internet. This journal is published at the Website <http://www.ijnrd.org>, maintained by IJNRD, Gujarat, India.

ISSN 2456-4184



9 772456 418401

# Editorial Board member

**RAJESH KUMAR.C**

Ph.D (MAGADH UNIVERSITY)

ASSOCIATE PROFESSOR, JEPPIAAR INSTITUTE OF TECHNOLOGY

**Sivasakthivel Senthilvel**

PhD. (Pursuing)

Research Scholar, Department of Environmental Science

**Dr. N.Ramu**

PhD

Associate Professor, Annamalai University

**Prof. Vinod Thumar**

PhD(Cont.)

Head of Department, Sabar Institute of Technology for Girls

**Dr. P Ravinder Reddy**

PhD

Head of Department, Chaitanya Bharathi Institute of Technology, Osmania University

**Dr. Varaprasad S Kondapalli**

PhD

Principal, Central India College of Engineering

**Dr. Lalchand Pandhariji Dalal**

PhD

Associate Professor, R.T.M.Nagpur University,Nagpur(M.S).

**Prof. Shailesh Patel**

PhD(Cont.)

Asst. Prof., S.P.B.Patel Engg. College

**Dr. V. R. Pramod**

PhD

Associate Professor, NSS College of Engineering

**Dr. Moinuddin Sarker**

PhD(UMIST, Manchester, UK), MCIC, FICER, MInstP, MRSC\*)

Vice President , Research and Development (R & D), Head of Science Team (VP and CTO)

**Prof.R.N.Patel**

PhD(Cont.)

P.G. Coordinator, Saffrony Institute of Technology

**Prof. Siles Balasingh**

M.Tech

Head of Department, St. Joseph University, Tanzania

**Dr. R Balu**

PhD

Professor, Bharathiar University, Coimbatore

Sohail Ayub

Associate Professor

Ph.D, Z.H. College of Engg. & Tech AMU Aligarh

Dr Neetha John

PhD

Principal, K J institute of engineering and Technology

Prof. Kamlesh Patel

PhD(Cont.)

Head of Department, R K University

Dr. PATHIK MAHENDRAKUMAR SHAH

Ph.D. (VEER NARMAD SOUTH GUJARAT UNIVERSITY, SURAT)

ASST. PROFESSOR, CENTRAL INSTITUTE OF PLASTICS ENGINEERING & TECHNOLOGY (CIPET), AHMEDABAD

Dr. Dinesh Chandra Jain

PhD, SRTM (Govt. University ), Nanded

Associate Professor, Shri Vaishnav Inst. of Tech. & Science (SVITS), Indore.

Dr. V D N Kumar Abbaraju

PhD

Asst. Prof., GITAM University, Visakhapatnam

Dr. Chandrashekhar N. Sakhale

PhD

Lecturer, Priyadarshini College of Engineering, Nagpur

Dr. M A Patel

PhD

Principal, Saffrony Institute of Technology

Prof. Srinivasa Kishore Babu

PhD(Cont.)

Asst. Prof., JNTUK University College of Engineering, Vizianagaram

Dr. Sunil Kumar

PhD

Asst. Prof., National Institute of Technology, Jamshedpur

Dr. Nurul Fadly Habidin

PhD

Sr. Lecturer, Universiti Pendidikan Sultan Idris

Dr.Mohammad Israr

PhD

Principal, Balaji Engineering College

Dr. Radhashyam Giri

Ph.D. (Polymer Technology), Indian Institute of Technology Kharagpur

Assistant Professor, CIPET

Dr. Rajeev Vaghmare

Ph.D.

Principal, Sabar Institute of Technology for Girls Tajpur

Vishnu Narayan Mishra

Ph.D. (IIT Roorkee)

Assistant Professor, S.V. National Institute of Technology, Surat

Prof. Anand Nayyar

PhD(Cont.)

Asst. Prof., KCL Institute of Management and Technology, Jalandhar

Dr. Ussama Ibrahim Badawy

PhD

Head Architech Engineer, UNRWA, Gaza

Vijay V Rao

M.Sc ( Ph.D)

Assistant Professor, RNSIT

Dr. Nimish Vasoya

PhD

Head of Department, Sanjaybhai Rajguru College of Engineering

Prof. Vachik Dave

PhD(Cont.)

TA, Indiana University,(USA )

Dr. G. THAMIZHENDHI

Associate Professor & Head,PG Department of Mathematics

Associate Professor & Head,PG Department of Ma, Vellalar College for Women, Erode-638012, Tamilnadu

A Sudhir Babu

Ph.D

Professor, PVP Siddhartha Institute of Technology

A.Jesu Kulandairaj

MCom., MPhil.,PhD.,MBA

Assistant Professor, Loyola College

A.S. JALANDHARACHARI

PHD

PHD, PHD

Abd El-Aziz Ahmed

Ph.D

Cairo UNI, ISSR

Abhisek Swami

PHD

ASSOCIATE PROFESSOR, Dronacharya Group of Institutions Greater Noida

ABHISHEK TIWARI

Ph.D

ASSOCIATE PROFESSOR, srimt, Dr APJ Abdul Kalam Technical University Lucknow India

ABILASH

LMETE, LMIEI, LMISRD, MIAENG, MSDIWC, MIEDRC, MSCIEI

LECTURER, BTTI, PILANI, RAJASTHAN-333031, INDIA, LECTURER, BTTI, PILANI, RAJASTHAN-333031, INDIA

**Ajay Shriram Kushwaha**

PhD (Computer Science & Technology)

Assistant Professor, Lovely Professional University, Phagwara, Punjab

**Ajay Tripathi**

Ph.D.

Associate Professor, RJIT (An Inst. of Border Security force) Tekanpur Gwalior

**Ajeet Kumar Srivastav**

M.Sc.

Senior Research Fellow, CSIR-Indian Institute of Toxicology Research

**Akhilesh Khapre**

PhD

Faculty, NIT Raipur

**AKSHEY BHARGAVA**

BTECH,MTECH.,ph.D, LLB

PROFESSOR, GLOBAL INSTITUTE OF ENGINEERING AND TECHNOLOGY, HYDERABAD, A.P, INDIA

**ALAGURAJA**

M.Sc.,M.Tech.,PhD.,PDF.,

RESEARCH SCIENTIST, MADURAI KAMARAJ UNIVERSITY

**AMARENDRA MATSA**

Ph.D

Professor, KITS Guntur

**AMISH**

M.A., Ph. D.

ASSISTANT PROFESSOR, DEPARTMENT OF PSYCHOLOGY, FEROZE GANDHI COLLEGE (C.S.J.M. UNIVERSITY, KANPUR), RAEBARELI

**Amol Murgai**

Ph.D, M.B.A(Marketing), B.E(Mechanical)

Associate Professor, International Centre of Excellence in Engineering and Management, Aurangabad

**Amol Ubale**

Ph.D. Mechanical Engineering

Associate professor and Head of Mechanical Departm, Zeal College of Engineering and Research Pune

**Amrina Shafi**

PhD

Research Associate, University of Kashmir

**ANAND GNANA SELVAM S**

Ph.D

Head cum Assistant Professor , AET COLLEGE SALEM

# FABRICATION OF SOLAR POWERED HACKSAW

<sup>1</sup>ABHIJEET MAURYA, <sup>2</sup>ABDUL MOQEEM

<sup>1</sup>UG Student, <sup>2</sup>UG Student

Dr. A.P.J.ABDUL KALAM TECHNICAL UNIVERSITY LUCKNOW INDIA

**ABSTRACT:** *This project is on the design and construction of a solar power hacksaw machine for cutting of metal to different size and length with the help of solar hacksaw. The objective of this project is to save manpower and time, energy in cutting metals in order to achieve high productivity. It is a cutting machine with teeth on its blade used specially for cutting material. The power to the hacksaw is provided by the Solar Energy. The motor drives the flywheel connected to the shaft of the motor. The flywheel is connected through a link that transmits the required force for cutting the work piece. Finally connecting rod is connected to the vertical arm connected to the horizontal arm. Rotary motion of the shaft is converted into reciprocating motion of the hacksaw with the help of crank and connecting rod. Work piece of desired length can be cut by feeding it to hacksaw by holding it into bench vice. The various component of the machine were designed and constructed. Test was carried out on the machine using different metals.*

*A solar panel connected to power hacksaw is considered as a solar operated power hacksaw in which sun's energy is used to drive the hacksaw in order to cut wood, metal rod etc. A solar connected to the hacksaw converts the solar energy into electrical energy which is stored in a 12 v battery as a direct current to run the motor connected to the hacksaw .A DC motor is connected to the hacksaw which is used to give the rotary motion to the flywheel connected to the shaft of the dc motor .The energy stored in battery is supplied to the dc motor which rotates the flywheel connected to the shaft of motor.*

*The rotary motion of the flywheel is converted to reciprocating motion which gives back-forth motion to blade of the hacksaw by a mechanism known as scotch yoke mechanism. The reciprocating motion of the hacksaw reciprocates the blade on the work piece which performs the cutting action. The work piece is clamped in a clamper to fix it. The clamper is made of cast iron or mild steel. A solar power hacksaw is a cheap and environmental friendly device that is operated without the consumption of any energy other than the solar energy .Solar energy is cheap and easily available on the earth. No heavy machines or devices are required for energy conservation. Solar powered hacksaw can be used in work shop, industries, and many fields where there is a requirement of hacksaw.*

**Keyword-** Solar Panel, DC Motor, Battery, Flywheel, Mild Steel

## CHAPTER 1 INTRODUCTION

### 1.1. General

A hacksaw is a handheld tool used to cut through materials like plastic tubing and metal pipes. Its cutting mechanism is provided by removable blades which feature sharp teeth along their outer edge. In most cases, a hacksaw consists of a metal frame that resembles a downward-facing. A handle of plastic, wood, or metal is typically affixed to one end of the frame. The frame's ends feature adjustable pegs that can be tightened to secure a blade in place, and loosened to remove it. Hacksaw blades are long, thin strips of hardened steel that feature a row of teeth along their cutting edge. Each end of the blade is punched with a small hole that fits onto the saw frame's pegs. Most blades range in length from ten to 12 inches (25.4 to 30.48 cm), although six-inch (15.24 cm) blades can be purchased to fit smaller hacksaw models. A device that applies force, changes the direction of a force, or changes the strength of a force, in order to perform a task, generally involving work done on a load. Machines are often designed to yield a high mechanical advantage to reduce the effort needed to do that work. A simple machines a wheel, a lever or an inclined plane. All other machines can be built using combinations of these simple machines. Example: A drill uses a combination of gears (wheels) to drive helical inclined planes (the drill bit) to split a material and carve a hole in it.

### 1.2. Scope of the project

1. The machine can solve the problem of time consumption.
2. Waste of resources in face of labor cost is reduced.
3. The machine can be used in the industry where it is manufactured, at the packaging sector.
4. 4 It is used as hardware in large quantity like in fabrication machine
5. It provide alternative for industries aiming toward reducing human effort.
6. It generates sustainable and practical solutions for the future industrial development.

### 1.3. Objectives of the project

1. To cater to the issue of competition in mechanical industry the need for solar energy is assess by all the industry.
2. Identify the key policy avenues considered to be appropriate to meet the challenge of sustainable manufacturing and packaging industry for the future.
3. To provide alternative for industries aiming toward reducing human effort.
4. Sustainable and practical solutions for the future industrial environment.

### 1.4. Approach and Methodology:

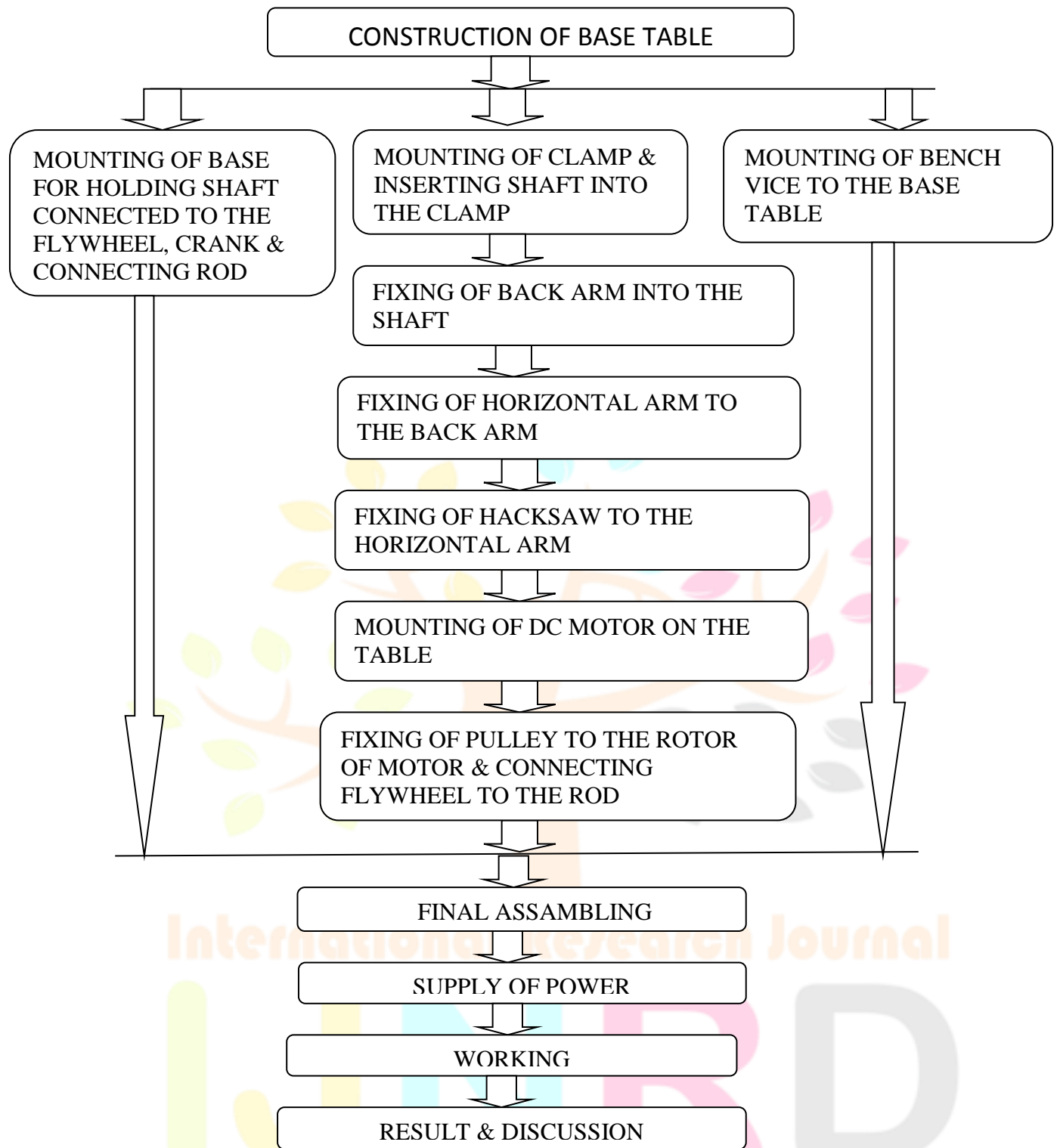

### 1.5 Justification & Relevance

We have found a solar power hacksaw to be the most useful for general shop work. Modern heavy-duty hacksaw machines provide an economical and efficient means of sawing a wide range of materials and stock sizes. Power hack saws are getting rarer all the time but they do a good job within their capacity. If you can get one that takes standard hacksaw blades then you'll have a tremendous range of blades to choose from and will be able to cut most anything. Solar Hacksaws are more tolerant to tensioning maladjustment and run off. A major advantage of solar power hacksaw cutting is the relatively low capital investment required. Tooling and maintenance costs are low. Accuracy and finishes produced, range from fair to good depending on the material being sawed. Time saving as compared to simple hacksaw and comfortable than ordinary hacksaw.

## CHAPTER 2

### LITERATURE REVIEW

#### 2.1 General

After the study of many literatures about design, construction and working of solar power hacksaw machine, some of them describe the methodology of solar power hacksaw. Lots of factor have been consider for the design, construction and working of solar power hacksaw machine such as cutting speed, cutting material, cutting time ,power ,efficiency etc. So, lots of literatures have been found which gives the relevance information and methodology of constructing an solar power hacksaw machine.



## 2.2 Historical Background

The problem of cutting-off material to size is common to practically every industry. Often, sawing is the first operation carried out on bar stock. Therefore, it is surprising that so little work has been done to understand the problems of this common operation. Many reasons have been considered better methods. Often the foreman will assign a new trainee to a sawing task, on the principle that it is easy to learn and difficult to foul up. Furthermore cut-off machines are frequently housed in stores away from the main production areas and the operation of the sewing machines appears to be simple. The fact remains that cutting-off operations can account for a significant part of the cost per piece (Remmerswaa and Mathysen, 1961).

The reason for carrying out the present work is the growing realization on the part of manufacturers of both blades and machines, that the factors which control the mechanics and economics of power hacksaw cutting are complex. Also power hacksaw cutting has been receiving increased competition from other cutting off processes, such as band and circular sawing.

Whilst the British Standard BS 1919: 1974 gives specifications for hacksaw blades regarding dimensions etc. the standard relates to testing of hacksaw blades for hand use only and does not include power hacksaw blade testing. Thus, both manufacturers of hacksaw blades and users have experienced considerable difficulty in establishing standard testing procedures and in obtaining consistency in test data using power hacksaw machines. Preliminary investigations by the author have revealed that existing blade testing methods were not independent of the machine characteristics, which could contribute to one of the reasons for the inconsistency in the test data. Hence, there has been requirement to identify the machine characteristics under normal working conditions and to investigate the mechanics of the sawing process and the variables affecting metal removal rate. Most of the early published work on cutting-off has been primarily concerned with circular and band sawing and cost comparisons between alternative processes. Whilst these alternative processes are frequently, quicker than power hacksaw cutting, their costs are in many applications higher. Whilst the impact of these alternative processes on the application of power hacksaw cutting cannot be denied there remains a significant field of application for power hacksaw cutting which is likely to remain unchallenged. A factor of prime interest to manufacturers is that, if the costs of power hacksaw cutting can be reduced by developing the blade and the saw machine, the potential field of application will be widened. During the past fifty years very little attention has been devoted to developing the geometry of the hacksaw blade or the machine, although, some improvements in the blade material, together with methods of applying the load and mechanized work handling, have been achieved (Nelson, 1965).

## 2.3 Sawing

If all raw stock was delivered in ready-to-machine shapes and sizes, there would be no need for sawing machines in a metal working shop. Machine operators could merely go over to the stock, select the suitable work piece, and perform the necessary finishing operations. Such situation rarely exists, due to the fact that the majority of the stock requires to be cut in some way prior to starting a machining schedule. The alternative to this primary operation of sawing is to buy-in prepared lengths and shapes; this however introduces a service which the company has to pay for and, in the majority of the cases, it is simpler and more economical to carry out the basic cutting-to-size operation in house. One of the major advantages of sawing over all other kinds of machining is the narrowness of cut. Most sawing machines perform the cut-off operation, where a piece of stock is cut to a workable length prior to subsequent machining operations. Machines that accomplish this job include hacksaws, band saws and circular saw.

## 2.4 Power Hacksaw Cutting

The simple back-and-forth motion of the blade made the hacksaw one of the first types of sawing machines designed for power. The simplicity in the blade motion has kept the price of the saw machine relatively cheaper than other types of sawing machines. The low initial cost coupled with the flexibility and adaptability, has enabled the hacksaw to remain popular in industry. In hacksaw cutting, a single blade is tensioned in the bow, and reciprocated back and forth over the work piece. The cutting action is achieved only during half of the cycle of operation. During the second half of the cycle, the return stroke, the blade is lifted clear of the work piece, giving a discontinuous cutting action, which is considered to be one of the drawbacks of the operation. Despite this disadvantage, As compared to the continuous-cutting action of the band saw, hacksaws remain equally or even more popular alternative machines. As with many other basic processes, hacksaw cutting is a tried and tested method, reliable, consistently accurate, quick and easy to repair, is less dependent on correct blade tension and less likely to run-out. Furthermore power hacksaws can be left unattended for long periods when cutting large diameter bar and require minimum operator skill. Blade replacement is relatively cheap and simple.

## 2.5 Types of Hacksaw Cutting Machines

For a given blade and work piece the material removal rates achieved by hydraulic and gravity fed machines are controlled solely by the thrust loads developed. Therefore, hack sawing may be said to be a process in which the material removal rate is force controlled, unlike most other material removal processes. The machines available can be divided into two broad categories, according to the method used to develop the load between the blade and the work piece, namely gravity feed machines and hydraulic machines. A third, but not common machine is the positive displacement machine. Power hacksaw machines are used mainly for cutting-off operations.

### 2.5.1. Gravity Feed Machines

In this type of machine, which is usually of light construction for general duty, the thrust load is developed by the gravity feed of the saw bow. In many of these machines the magnitude of the thrust load is fixed, although some machines are provided with adjustable masses on the over arm for thrust load adjustment. The thrust, load varies throughout the cutting stroke due to the reciprocating displacement of the over arm mass and the action of the cam operated lift-off device which acts at the beginning and the end of the stroke. This type of machine generally has a work piece capacity between 150 - 200 mm (6 and 8 inches) diameter and is ideal for the small workshop where the cutting requirement is only occasional and the configuration of work pieces to be cut ranges from mild steel flat complex shaped sections and tubular sections up to 6 inches diameter. Due to the light construction and gravity feed the applications for this type of machine are limited.

### 2.5.2. Hydraulic Machines

The thrust force between the blade and the work piece in this type of machine is developed by a hydraulic device. Pressure may be developed in the load cylinder by either a restricted back-flow system, or the pressure may be supplied from a separate pump. In some of these machines, greater flexibility of control has been introduced by means of an arc cutting action combined with a universally controlled hydraulic system which allows better performance from the saw blade. The advanced types of heavy duty electro-hydraulic hacksaws have a

very wide range of operation and are available in semi-automatic or fully automatic form, with provisions for automatic feeding of bar stock, cutting-off to predetermined sizes and unloading etc. The feature of power down-feed to the saw bow incorporated in these machines makes the machine suitable for cutting the tougher steels and alloys. These machines are the most common and develop greater thrust loads than machines of other type and have a reputation for sawing without problems and requiring minimum operator skill.

### 2.5.3. Positive Displacement Machines

Whilst these machines are not as popular as the gravity feed or hydraulic machines, a few machines are available where the feed rate of the blade and hence, the metal removal rate is directly controlled by a mechanical screw device, giving a positive feed. This type of machine can lead to overloading of the blade giving premature blade failure particularly when the blade is worn. Positive displacement machines are not prone to variation in thrust loads during the cutting stroke-since the thrust loads directly arise as a result of the constant rate of penetration of the blade teeth.

### 2.6 Band Sawing

Band sawing, unlike hacksaw cutting, is a continuous cutting operation. An endless blade, the band, is tensioned between two shrouded, rotating wheels, and part of the band is exposed to carry out the cutting operation of the work piece. The band travels in a continuous motion, with the teeth fed against the work piece. Whilst earlier metal sawing bands were wide (over 25 mm), and were used strictly for cut off methods, narrow blades, introduced about 50 years ago brought contouring capabilities. Furthermore, due to the small throat clearance of the early band saws, they were limited in use by the basic design, thus the length of the work piece could only be as long as the machine throat. However modern machines have been modified to give adequate throat clearance, by intentionally twisting the blade so that the toothed faces in line with the machine throat. As with hacksaw machines, band saws can be divided into two broad categories. A general purpose band saw having gravity fed system, controlled by a dash-pot and using a 25 mm (1 inch) deep blade, is the most popular machine available. This machine is suitable for general fabrication work and accurate cutting of solid bars. This type of machine is limited to about 175 mm (7 inches) diameter for mild steel. In order to meet the present day requirements for high-volume production, cutting all grades of steel and to introduce high accuracy and reliability, it has been necessary for the band saw machine manufacturers to incorporate in the design not only heavy duty construction having capacities up to 450 mm (18 inches) diameters but also innovations in the hydraulic power down-feed, to allow the cutting of difficult alloys such as mnemonics and titanium.

### 2.7 Circular Sawing

Circular saws have a continuous cutting action, use blades having many teeth, and a large range of Rotational speeds. This operation is similar to a milling operation. The machines available range from the earlier, inexpensive hand loaded models to the very large, power loaded type and incorporate material handling devices for semi and then fully automatic operations. Modern production circular saws are built with several alternate basic feed mechanisms i.e. horizontal, vertical, rocking head and variations of these. The choice of the most suitable type of machine depends on the particular application and the size and shape of component. With vertical feed, the rotating blade travels downwards in a straight line to engage the work piece. On machines designed for horizontal feed the blade is fed into the work piece from the back. A third basic feeding arrangement is a pivot motion or rocking-head system, this is as efficient as a vertical feed system and is a rugged arrangement. The bench or floor mounted manual-feed circular saw, when installed together with a general duty band saw or hack sawing a small workshop, provides a complete cutting facility for the small fabricator. Fully automatic circular saws, having features such as dial-in component length, in process gauging, choice of loading magazines, etc. are widely used where high quality production is required and often present the production engineer with a difficult choice to make between circular sawing and band sawing. (Suzuki etc.1998).

### 2.8 Features of Modern Hacksaw

The simplicity of design and operation, coupled with the low initial cost, has made the hacksaw grow in popularity. Its limitations are due to its mode of operation, i.e. cutting only on half of the stroke, the slow cutting speed, and the fact that not all the length of the blade is utilized.

Some of the features in a modern hacksaw which achieve improved performance are:

- I. A range of cutting speeds, uniform over the cutting stroke, and a fast return stroke.
- II. Means to regulate and monitor the cutting pressure.
- III. Adjustable stroke.
- IV. Automatic relief of the blade on the return stroke.
- V. Some means of indicating and correcting blade tension.
- VI. Automatic stopping device when the cut is complete.

## CHAPTER 3

### PROJECT METHODOLOGY

#### 3.1 General

Solar Power Hacksaws are used to cut large sections of metal or plastic shafts and rods. Cutting of solid shafts or rods of diameters more than fifteen millimeters is a very hard work with a normal hand held hacksaw. Therefore solar power hacksaw machine is used to carry out the difficult and time consuming work. This power hacksaw machine is considered as an energy saving machine because the operator need not be there to provide the reciprocating motion and downward force on the work-piece in order to cut it. Once the operator has fed the work-piece till the required length in to the machine and starts the machine, then the machine will cut until the work-piece has been completely cut in to two pieces. The Solar Power hacksaw machine though being able to cut the shaft or rod without requiring any human effort to cut, it does require a human intervention to feed the work-piece many times with measurements being taken each time before feeding.



Fig.3.1 (SOLAR POWERED HACKSAW)

### 3.2 Scotch yoke mechanism:

This mechanism is used for converting rotary motion into a reciprocating motion. The inversion is obtained by fixing either link 1 or link 3. In fig link 1 is fixed. In this mechanism when the link 2 (which correspond to crank) rotates about Bas centre, the link 4 (which correspond to frame) reciprocates. The fixed link 1 guides the frame.

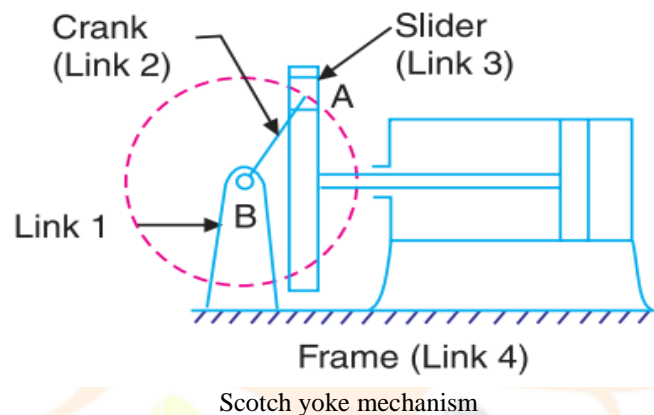

### 3.2 Components Used

Following components has been used to construct this project

#### 3.2.1 Flywheel:

Flywheel used in machines serves as a reservoir which stores energy during the period when the supply of energy is more than the requirement and releases it during the period when the requirement of energy is more than supply. Flywheels have a significant moment of inertia and thus resist changes in rotational speed. The amount of energy stored in a flywheel is proportional to the square of its rotational speed. Energy is transferred to a flywheel by applying torque to it, thereby increasing its rotational speed, and hence its stored energy. Conversely, a flywheel releases stored energy by applying torque to a mechanical load, thereby decreasing the flywheel's rotational speed. Flywheels are typically made of al and rotate on conventional bearings; these are generally limited to a revolution rate of a few thousand RPM .Some modern flywheels are made of carbon fiber materials and employ magnetic bearings enabling them to revolve at speeds up to 60,000 RPM. In case of steam engines, internal combustion engines, reciprocating compressors and pumps, the energy is developed during one stroke and the engine is to run for the whole cycle on the energy produced during this one stroke. For example, in I.C. engines, the energy is developed only during power stroke which is much more than the engine load, and no energy is being developed during suction, compression and exhaust strokes in case of four stroke engines and during compression in case of two stroke engines. The excess energy developed during power stroke is absorbed by the flywheel and releases it to the crankshaft during other strokes in which no energy is developed, thus rotating the crankshaft at a uniform speed. A little consideration will show that when the flywheel absorbs energy, its speed increases and when it releases, the speed decreases. Hence a flywheel does not maintain a constant speed; it simply reduces the fluctuation of speed. In machines where the operation is intermittent like punching machines, shearing machines, riveting machines, crushers etc., the flywheel stores energy from the power source during the greater portion of the operating cycle and gives it up during a small period of the cycle. Thus the energy from the power source to the machines is supplied practically at a constant rate throughout the operation.

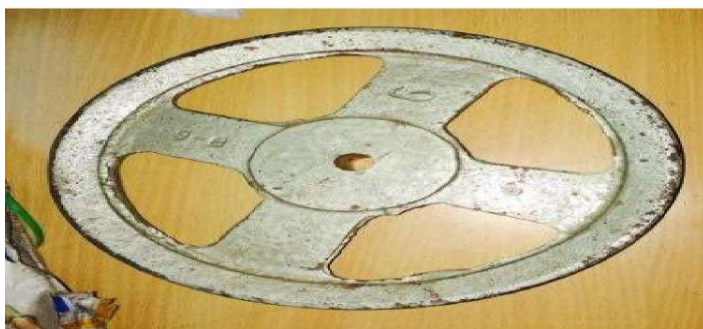

Fig. 3.2.1(a) Flywheel



Fig.3.2.1 (b) Flywheel

Flywheels are often used to provide continuous energy in systems where the energy source is not continuous. In such cases, the flywheel stores energy when torque is applied by the energy source and it releases stored energy when the energy source is not applying torque to it. For example, a flywheel is used to maintain constant angular velocity of the crankshaft in a reciprocating engine. In this case, the flywheel—which is mounted on the crankshaft—stores energy when torque is exerted on it by a firing piston, and it releases energy to its mechanical loads when no piston is exerting torque on it. Other examples of this are friction motors, which use flywheel energy to power devices such as toy cars.

### 3.2.2 Hacksaw

A hacksaw is a fine-tooth saw with a blade under tension in a frame, used for cutting materials such as metal. Hand-held hacksaws consist of a metal frame with a handle, and pins for attaching a narrow disposable blade. A screw or other mechanism is used to put the thin blade under tension.

A power hacksaw (or electric hacksaw) is a type of hacksaw that is powered by electric motor. Most power hacksaws are stationary machines but some portable models do exist. Stationary models usually have a mechanism to lift up the saw blade on the return stroke and some have a coolant pump to prevent the saw blade from overheating. Hacksaw blades (both hand & power hacksaw) are generally made up of carbon steel or high speed steel strip rolls. The blank of required size is obtained by fixing the strip rolls on the stand of semi-automatic strip cutting machine and punched a hole at their both ends. Then, teeth are being made on the blank by milling or hobbling process. Once teeth are being cut, the hacksaw blades are heat treated and tempered for the required hardness. The last step in the manufacturing process is surface cleaning, painting, printing and packing of the hacksaw blades for market supply.



Fig. 3.2.2 Hacksaw Blade

### Selecting a Power Hacksaw blade

Proper blade selection is important. Use the three-tooth rule at least three teeth must be in contact with the work. Large sections and soft materials require a coarse-tooth blade. Small or thin work and hard materials require a fine-tooth blade. For best cutting action, apply heavy feed pressure on hard materials and large work. Use light feed pressure on soft materials and work with small cross sections. Blades are made in two principal types: flexible-back and all-hard. The choice depends upon use.

- **Flexible-back blades** -should be used where safety requirements demand a shatterproof blade. These blades should also be used for cutting odd-shaped work if there is a possibility of the work coming loose in the vise.
- **All-hard blade** -For a majority of cutting jobs, the all-hard blades best for straight, accurate cutting under a variety of conditions. When starting a cut with an all-hard blade, be sure the blade does not drop on the work when cutting starts. If it falls, the blade could shatter and flying.

Blades are also made from tungsten and molybdenum steels, and with tungsten carbide teeth on steel alloy backs. The following “rule-of-thumb” can be followed for selecting the correct blade: Use a 4-tooth blade for cutting large sections or readily machined metals. Use a 6-tooth blade for cutting harder alloys and miscellaneous cutting. Use 10- and 14-tooth blades primarily on light duty machines where work is limited to small sections requiring moderate or light feed pressure cause injuries.



### 3.2.3 DC MOTOR

This Dc or direct current motor works on the principal, when a current carrying conductor is placed in a magnetic field. it experiences a torque and has a tendency to move. this known as motoring action. If the direction of electric current in wire is reversed, the direction of rotation is also reverses. When magnetic field and electric field interact they produce mechanical force, and based on the working principal of DC motor establish.



Fleming's Left hand rule

The direction of rotation of this motor is given by Fleming's left hand rule, which states that if the index finger, middle finger and thumb of your left hand are extended mutually perpendicular to each other and if the index finger represent the direction of magnetic field, middle finger indicate the direction of current, then the thumb represent the direction in which the force is experienced by shaft of the DC motor. DC motor consist of one set of coils, called armature winding, inside another set of coil or a set of permanent magnet, called the stator. Applying a voltage to the coil produces torque in the armature, resulting in motion.



Fig. 3.2.3 (DC MOTOR)

**STATOR:**

- The stator is the stationary part outside the motor.
- The stator of permanent magnet Dc motor is composed of two or more permanent magnet pole pieces.
- The magnetic field can alternatively be created by electromagnet. In this case DC coils (field winding) is wound around a magnetic material that forms part of stator.

**ROTOR:**

- The rotor is the inner part which rotates.
- The rotor is composed of winding (called armature winding) which are connected to the external circuit through a mechanical commutated.
- Both stator and rotor are made of ferromagnetic materials. The two are separated by air gap.

**WINDING:**

A winding is made up of series and parallel connection

- Armature winding- the winding through which the voltage is applied or induced.
- Field winding- the winding through which the current is passed to produced current(for the electromagnet).
- Winding are usually made of copper

**3.2.4 Bolt and Nuts**

A screw thread is formed by cutting a continuous helical groove on a cylindrical surface. A screw made by cutting a single helical groove on the cylinder is known as single threaded (or single-start) screw and if a second thread is cut in the space between the grooves of the first, a double threaded (or double-start) screw is formed. Similarly, triple and quadruple (i.e. multiple-start) threads may be formed. The helical grooves may be cut either right hand or left-hand. A screwed joint is mainly composed of two elements i.e. a bolt and nut. The screwed joints are widely used where the machine parts are required to be readily connected or disconnected without damage to the machine or the fastening. This may be for the purpose of holding or adjustment in assembly or service inspection, repair, or replacement or it may be for the manufacturing or assembly reasons. The parts may be rigidly connected or provisions may be made for predetermining.

**Advantages and Disadvantages of Screwed Joints:****(a) Following are the advantages of the screwed joints:**

1. Screwed joints are highly reliable in operation.
2. Screwed joints are convenient to assemble and disassemble. A wide range of screwed joints may be adapted to various operating conditions.
3. Screws are relatively cheap to produce due to standardization and highly efficient manufacturing processes.

**(b) Following are the disadvantages of the screwed joints:**

The main disadvantage of the screwed joints is the stress concentration in the threaded portions. Which are vulnerable points under variable load conditions.

**(c) Important Terms Used in Screw Threads**

The following terms used in screw threads are important from the subject point of view:

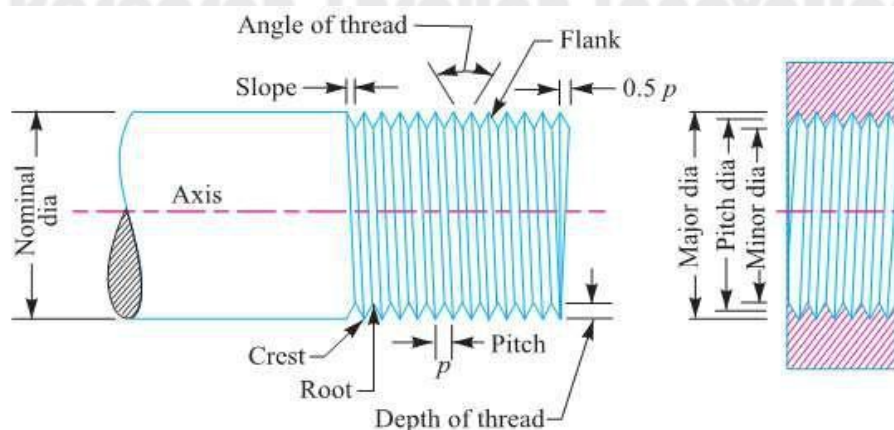

Fig.3.2.4 Screw Threads

1. **Major diameter.** It is the largest diameter of an external or internal screw thread. The screw is specified by this diameter. It is also known as outside or nominal diameter.
2. **Minor diameter.** It is the smallest diameter of an external or internal screw thread. It is also known as core or root diameter.
3. **Pitch diameter.** It is the diameter of an imaginary cylinder, on a cylindrical screw thread, the surface of which would pass through the thread at such points as to make equal the width of the thread and the width of the spaces between the threads. It is also called an effective diameter. In a nut and bolt assembly, it is the diameter at which the ridges on the bolt are in complete touch with the ridges of the corresponding nut.
4. **Pitch.** It is the distance from a point on one thread to the corresponding point on the next. This is measured in an axial direction between corresponding points in the same axial plane Mathematically,

$$\text{Pitch} = \frac{1}{\text{No. of threads per unit length of screw}}$$

5. **Lead.** It is the distance between two corresponding points on the same helix. It may also be defined as the distance which a screw thread advances axially in one rotation of the nut. Lead is equal to the pitch in case of single start threads; it is twice the pitch in double start, thrice the pitch in triple start and so on.
6. **Crest.** It is the top surface of the thread.
7. **Root.** It is the bottom surface created by the two adjacent flanks of the thread.
8. **Depth of thread.** It is the perpendicular distance between the crest and root.

### 3.2.5 SOLAR PANEL

A solar panel designed to absorb the sun's rays as a source of energy for generating electricity. A photovoltaic (in short PV) module is a packaged, connected assembly of typically  $6 \times 10$  solar cells. Solar Photovoltaic panels constitute the solar array of a photovoltaic system that generates and supplies solar electricity to store in battery and run motor. Each module is rated by its DC output power under standard test conditions, and typically ranges from 100 to 365 watts. The efficiency of a module determines the area of a module given the same rated output – an 8% efficient 230 watt module will have twice the area of a 16% efficient 230 watt module. There are a few solar panels available that are exceeding 19% efficiency. A single solar module can produce only a limited amount of power; most installations contain multiple modules. A photovoltaic system typically includes a panel or an array of solar modules, a solar inverter, and sometimes a battery and/or solar tracker and interconnection wiring. Solar modules use light energy (photons) from the sun to generate electricity through the photovoltaic effect. The majority of modules use wafer-based crystalline silicon cells or thin-film cells based on cadmium telluride or silicon. The structural (load carrying) member of a module can either be the top layer or the back layer. Cells must also be protected from mechanical damage and moisture. Most solar modules are rigid, but semi-flexible ones are available, based on thin-film cells. Electrical connections are made in series to achieve a desired output voltage. Bypass diodes may be incorporated or used externally, in case of partial module shading, to maximize the output of module Sections still illuminated.



Fig. 3.2.5 (Solar panel)

### Components of Photovoltaic Cells:

1. **Photovoltaic Effect:** PV cells are able to create electricity at the atomic level using the photovoltaic effect. Often the photovoltaic effect is confused with the photoelectric effect. One is related to the other as both begin with the basic understanding that the universe is created of two core entities: matter and energy. Matter is anything that has mass and takes up space. In physics energy is defined as a source providing the ability to do work (e.g. light, heat, sound, electricity). In the photoelectric effect, there are two components: photons (energy) and electrons (matter). Photons are light “packets”. Each one carries a specific quantity (quanta) of energy revealed in different frequencies of light (higher energy photons are found in higher frequencies of light waves). Using the correct light frequency (photons) focused on a material (usually metal), it is possible to knock off or release electrons. So, the photoelectric effect uses light to eject electrons. Similarly, in the photovoltaic effect photons are used to eject the electrons, but these electrons are harnessed to produce an electric current or electricity.
2. **Semi-Conductor:** The flow of electrons or an electric current is possible within the photovoltaic effect if a conductor is present. Electricity is conducted through a material by moving electrons through orbital's at varying energy levels in atoms. Electrons move from lower energy levels (valance band) to higher energy levels (conduction band). The energy difference between these levels is known as the band gap. Semi-conductors have an intermediate band gap. Meaning they require more energy to move electrons than a conductor, but less than an insulator. Once electrons are moved they create electron “holes” or unoccupied orbital's in the valance band and easily released electrons in the conduction band. In PV cells, semi-conductors are often used because they can regulate conduction band electrons and electron “holes” more readily, especially if the semi-conductor is “doped” or impurities are added.

- 3. P-N Junction (Photodiode):** The photovoltaic effect within a PV cell is able to produce an electric current by using a P-N junction. The P-N Junction is made of two kinds of semi-conductors. The N-type (N for Negative or electron-rich) is doped to have a high density of electrons and few holes, while the P-type (P for Positive or electron-poor) is doped to be the opposite. Electrons flow from areas of high to low concentration. The difference between these concentrated areas is known as voltage. A P-N junction regulates the voltage, so current only flows in one direction resulting in an electric current.

#### Operation of Photovoltaic Cells (Solar Cells):

PV Cells are able to convert light into electricity by first allowing radiant energy from the sun to pass through a transparent layer (glass). A small portion of the light frequencies (10 – 17% with technology commercially available in 2011) (photons) are absorbed ejecting electrons from the doped N-type semiconductor layer. The amount depends on intensity and angle of light sent and the continuing development of the manufacturing technology. These electrons are passed to a conductor, which completes a circuit back to the P-type semiconducting layer. After transporting electrical energy utilized by electrical devices or stored in batteries, the electrons will fill “holes” in the P-type semiconducting layer. Due to electrons being deposited in P-type semiconductor layer the voltage increases forcing the electrons to move across the junction into the N-type semiconductor allowing the process to repeat it. As technology advances, improvements in conversion efficiencies demonstrated in the laboratory (some approaching 40%) may become commercially available, subsequently lowering costs.

#### Determining Size of Photovoltaic Panel Array:

There are several steps involved in sizing the PV array, determining load power consumption, accounting for losses and dividing by solar insulation levels for deployment region. Determining the Load Power Consumption. The first step is to determine how much power the total system load will draw. Power is measured in Watts.

$$P = V * I \text{ (Joule's Law)}$$

However, the power rating is more useful when looked at in terms of time, this is indeed how electric companies charge consumers. For example a 200Watt light bulb running for 24 hours uses 4.8 KWh.

$$200\text{Watts} * 24\text{hrs} = 4800 \text{ Watt-Hours or } 4.8 \text{ KW}$$

#### Determining Solar Insulation Levels:

In order to determine a good approximation of how much power the PV panels will output, solar insulation levels need to be considered. Solar insulation is the amount of incoming solar radiation incident on a surface, for PV applications the surface of interest is the earth's surface. The values of solar insulation are commonly expressed in kWh/m<sup>2</sup>/day, which is the amount of solar energy that strikes a square meter of the earth's surface in a single day. This is commonly referred to as a “Sun-Hour-Day”. The amount of insulation received at the surface of the Earth is controlled by the angle of the sun, the state of the atmosphere, altitude, and geographic location.

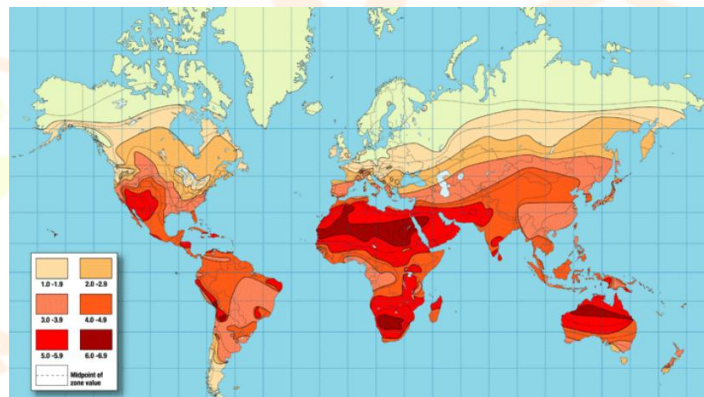

World's insulation levels.

This map divides the world into six solar performance regions based on winter peak sun hours. It is important to keep this in mind when designing the system because as seen below in Figure, during the winter you have a much smaller ‘Solar Window’. Worst case scenarios should be calculated as it is better to have extra energy in the summer than not enough in the winter. Therefore the “Sun-Hour-Day” values for December (since December days are shortest) are generally used.

#### 3.2.6 Rechargeable Battery

Nearly all large rechargeable batteries in common use are Lead-Acid type, although there are three variations, flooded, gelled electrolyte (“Gel Cells”) and absorbed glass matt (“AGM”). Flooded is the oldest and cheapest technology used but can be dangerous, in case of a malfunction acid can spill. Gel Cells contain acid that has been “gelled” by the addition of Silica Gel, turning the acid into a solid mass, therefore even if the battery were cracked open, no acid would spill. Gel batteries need to be charged at a slower rate (capacity / 20) but this is not a concern in the PV setup as the panels will not be outputting nearly this much current. AGM batteries are the newest technology and have all the advantages of Gel Cells without the charging limitations. All deep cycle batteries are rated in amp-hours. An amp-hour (Amps x Hours) is one amp for one hour, or 10 amps for 1/10 of an hour and so forth. The accepted AH rating time period for batteries used in solar electric and backup power systems is the “20 hour rate”. This means that it is discharged down to 10.5 volts over a 20 hour period while the total amp-hours it supplies is measured (Wind sun).

A rechargeable battery, storage battery, secondary cell, or accumulator is a type of electrical battery which can be charged, discharged into a load, and recharged many times, while a non-rechargeable or primary battery is supplied fully charged, and discarded once discharged. It is composed of one or more electrochemical cells. The term “accumulator” is used as it accumulates and stores energy through a reversible electrochemical reaction. Rechargeable batteries are produced in many different shapes and sizes, ranging from button cells to megawatt systems connected to stabilize an electrical distribution network. Several different combinations of electrode materials and electrolytes are used, including lead–acid, nickel cadmium (Ni-Cad), nickel metal hydride (Ni-MH), lithium ion (Li-ion), and lithium ion polymer (Li-ion polymer). Rechargeable batteries initially cost more than disposable batteries, but have a much lower total cost of ownership and environmental impact, as they can be recharged inexpensively many times before they need replacing. Some rechargeable battery types are available in the same sizes and voltages as disposable types, and can be used interchangeably with them.



Fig. 3.2.6 (Rechargeable battery)

## I. TYPES OF BATTERIES:

The rechargeable battery used in ICE car is a single 12V lead-acid battery. The two main type of batteries used are nickel metal hydride and lithium ion. The name of the battery corresponds to electrolyte used and the material of electrode. Each type of batteries has different type of chemical reactions within its cell. The batteries also differ in their amount and type of harm in human, the environment, and society.

### LEAD-ACID BATTERIES:

The battery used in every internal combustion engine (ICE) car on the road is 12V lead-acid battery. This single battery is responsible for powering the alternator, or the engine starter. It also supplies the power to accessories that the car may have, such as the air-conditioning, radio, and power windows and locks etc.

### 3.3 Wire Sizing and Connections:

Another important consideration for the system is the electrical wiring. All wiring needs to safely accommodate the amount of current draw of the system with an acceptable amount of losses. In a DC system losses quickly become an issue. This is especially a concern PV systems as they can only handle a small voltage drop as there must be enough potential to charge the battery array, and of course it is good practice to keep energy loss sourced from the sun to a minimum. Generally a 3% drop between PV array and batteries is acceptable. Also, "any type of connection bigger than AWG 10 should have a proper compression connector, with appropriate joint compound and preparation. This does require special tools and dies. Otherwise you are running the risk of burning up your connections if you get any kind of heavy current flowing (Solar Forum)"

Losses associated with transmission of DC power:

$$CM = (22.2 * A * D) / VD$$

CM = Circular Mills in Copper

A = current in amps

D = one-way cable distance in feet

VD = Voltage Drop

22.2 = Constant for Copper

For wiring from the PV panels to charge controller the maximum PV short circuit current specification (from PV data sheet) is used

### 3.4 Fabrication:

Fabrication means providing a physical shape to the prepared model. Fabrication was mostly done using the metal parts. The base and the support structures were made using the parts. The fabrication of each part and mechanism are described in the following section.

#### Construction of base table:

It was made using wood.

#### Mounting of motor and flywheel

Motor of 70 RPM and 0.67 HP was placed on the base table. Flywheel of 12 cm diameter was fixed to the shaft of motor and then flywheel connected with rod.

#### Mounting of hacksaw to the horizontal arm and mounting of bench vice to the base table:

Hacksaw was mounted to the horizontal arm by two vertical arm of length 7.5 inch and 6 inch welded to the horizontal arm. After mounting hacksaw to the horizontal arm, bench vice was mounted to the base table by fixing it with nut and bolt of length 2 inch and diameter 8 mm.

### 3.4 Calculation

The torque of the DC motor must be increased so as to bring about the necessary power for cutting of work-pieces efficiently. This is achieved by coupling the rotor of the DC motor to a flywheel. So, this will reduce the rotating speed while increasing the torque. The flywheel is connected to the reciprocating mechanism.

Driving flywheel diameter = 0.12

Speed of motor, N = 70 rpm

Force = 1.146

Power = 0.67 hp = 0.504 kW

Power =  $2\pi NT/60$

Torque T = 68.78 N-m

### 3.5 Working Principle:

The aim of our project is to run the machine both DC as well as AC power. First of all we gain the energy from the solar power. This gained energy is stored in battery. Then we actuate the motor with the help of this battery power. This project is work under the scotch-yoke



mechanism. The scotch-yoke mechanism converts the rotating motion in the reciprocating motion. The machine has a prime mover at the bottom of machine. The flywheel is connected to motor shaft. The clamp is fixed with flywheel. The clamp is fixed with the shaft at one end this shaft is act as reciprocating motion through the crank. The hacksaw is connected to the shaft at the end. If the motor is turn-on the flywheel getting rotating motion that rotation motion convert into reciprocating motion under the scotch-yoke mechanism.

**Power Hack sawing:**

**A power hacksaw machine is designed primarily straight-line sawing. A typical sawing operation is lined below:**

Select a hacksaw blade of proper length for the machine and proper pitch for the material to be cut. Install the hacksaw blade with the teeth pointing downward and toward the motor end of the hacksaw machine. Check the alignment of vice and hacksaw blade and mount the work piece in the vice. Make the vice holds the work piece securely. Check the stroke of hacksaw machine and adjust if necessary. After adjusting the stroke, move the hacksaw blade and sewing machine frame through one cycle by hand to check the blade clearance at each end of the work piece. Readjust the position of vice if necessary. Position the hacksaw blade about ¼ inches above the work piece and set the feed control to its lightest feed setting. Set desired speed of hacksaw machine. Start the machine and let the blade feed lightly into the work piece for about ¼ inch. Readjust the feed to whatever the material will stand for normal cutting. Permit the hacksaw blade to cut completely through work piece. The blade frame will trip a switch on sawing machine bed to stop the sewing machine.

Power hacksaw machine are used to cut large size of metal such as steel. Cutting diameter is more than 10/15 mm is very hard work with a normal hand held hacksaw. Therefore power hacksaw developed to carry out the difficult and time consuming work. The heavy arm moves forwards and backwards, cutting on the backwards stroke.

The metal to be cut held in machine vice which is an integral part of base. Turning the handle tightens or loses the vice. The vice is very powerful and locks metal in position. When cutting is takes place, the metal especially blade heats up quickly. Coolant should be fed on to the blade, cooling it down and lubricating it as it cut through the metal. Without coolant the blade will over heat and break. This can be dangerous as blade can break with powerful force, shattering.

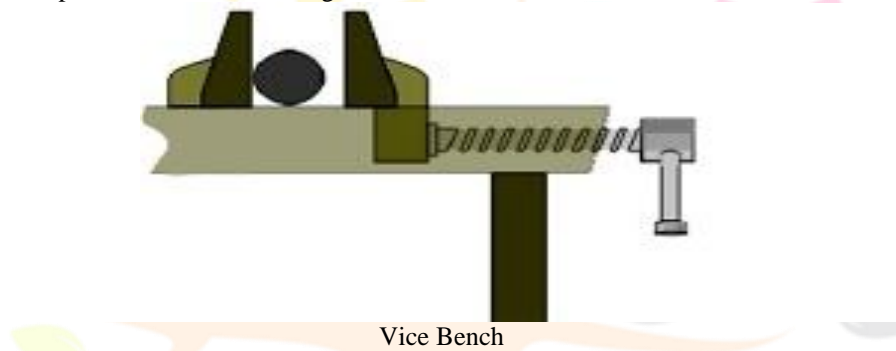

Blades of power hacksaw are graded according to the material they are made from and number of teeth per inch. Top quality blades are manufactured by High Speed Steel. Although there are cheaper alternative such as Carbon Steel Blades. In general the number of teeth per inch (TPI) range from 14 to 24.the more teeth per inch-the smoother to cut. The power hacksaw has electric motor that powers the blade through flywheel system. Some have ratchet system. The flywheel system transferred the rotary power from the motor and changed to reciprocating motion; allow the blade to cut through material.

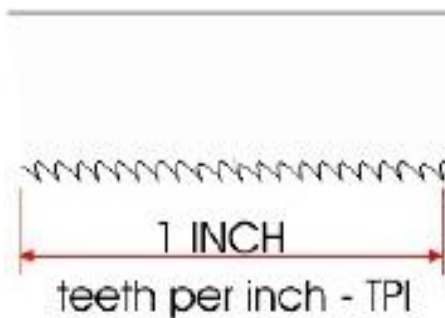

**3.5 Cost & Estimation**

Research Through Innovation

S.NO	COMPONENTS	QUANTITY	COST
1	D.C MOTOR	1	□ 1500
2	SOLAR PANEL	1	□ 550
3	FLY-WHEEL	1	□ 120
4	MILD STEEL FLAT ROD	2m	□ 200
5	NUTS AND BOLTS	15	□ 50
6	HACK-SAW BLADE	2	□ 20
7	Battery	1	□ 1800
8	Wire & Switch	2m&1	□ 40
	Total Cost		□ 4280

**CHAPTER 4****RESULT AND DISCUSSION**

Machine is driven by .67 HP and 70 rpm electric motor. Test was carried out on machine using different metal. For the loaded test, a shaft of diameter 25 mm and length 12 inch and the material of the shaft was mild steel was clamped on the vice of the machine. It took the machine 240 seconds to cut the with a new hacksaw blade. The cut was observed to be neat and straight. The total cost of equipment of the machine is Rs 4280. The total cost of producing the machine was estimated to be Rs10000. Recommendation has been made on the operation and parameters of the machine. Suggestion have been offered on overall machine performance optimization and further work on the machine.

**CHAPTER 5****CONCLUSION AND FUTURE SCOPE**

It is known that conventional hacksaw machine can be replaced with solar power hacksaw machine. Solar power hacksaw machine gives high productivity in short time period in comparison with the conventional hacksaw machines. The major advantage of this machine is that intervention of labor is reduced to maximum level. In this rapid emerging industrial era, the use of power Hacksaw machine is wide. Time and labor plays a major role in production process this can be overcome by using this type of machines. The solar hacksaw machine can be made use of at any of the industries like pump manufacturing industries that involve bulk amount of shafts that have to be cut frequently. The range of size of work-pieces that can be cut using the solar hacksaw machine can be varied by changing the blade size. Currently, the machine uses 12 inch blade for cutting.

**FUTURE SCOPE**

1. The machine can be fully operated by solar energy.
2. It has a wider application in remote areas which lacks supply of electricity.
3. It can also be used for cutting various materials like metals, wood, plastics etc

**REFERENCES**

- [1] Khurmi,R.S.,&J.K. Gupta (2014).Theory of Machines, S. Chand Publication[page no.114]
- [2] Khurmi, R. S., & Gupta, J. K. (2012). Machine Design, S. Chand Publication [page no.730]
- [3] Khurmi, R. S., & Gupta, J. K. (2012). Machine Design, S. Chand Publication [page no.998]
- [4] Kurvinen, E., Sopanen, J., & Mikkola, A. (2015). Ball bearing model performance on
- [5] various sized rotors with and without centrifugal and gyroscopic forces. *Mechanism and Machine Theory*, 90, 240-260
- [6] 5.Naresh,G.Venkatesh,N.S.Vishal,SureshKannan,Thangaprakash,A.Sivasubramanian, Dr.G.Arunkumar Design and Fabrication of Pedal Operated Hacksaw, 2014 3(11), 197-198
- [7] Nelson RE Bandsawing or hacksawing? 1965 109(24), Pages 90-93
- [8] Raj, K. J. S. D. (2012). *Modeling, Control and Prototyping of Alternative Energy Storage Systems for Hybrid Vehicles* (Doctoral dissertation, The Ohio State University).
- [9] Remmerswaal J Lp Mathysen MJC Economics of the cutting-off of metals *Microtecnic*, 1961 15(4), 140-150
- [10] Suzuki, A., Miyamoto, K., & Takahashi, S. (1998). *U.S. Patent No. 5,791,224*. Washington, DC: U.S. Patent and Trademark Office.
- [11] Thompson, P. J., & Sarwar, M. (1974, September). Power hacksawing. In *Proc. 15<sup>th</sup> IMTDR Conf.*
- [12] Usher, A. P. (2013). *A History of Mechanical Inventions: Revised Edition*. Courier Corporation.



# ENERGY MANAGEMENT SYSTEM WITH PROGRAMMABLE NUMBER USING GSM

Minesh N. Solanki<sup>1</sup>, Alpesh M.Radadiya<sup>2</sup>, Jaydip R.Parmar<sup>3</sup> and Harshad J.Bhaskar<sup>4</sup>

<sup>1,2,3</sup> Student of (Electrical Department) Dr. Subhash Technical Campus Junagadh, Gujrat, India.

<sup>4</sup> Asst. Professor of (Electrical Department) Dr. Subhash Technical Campus Junagadh, Gujrat, India.

**ABSTRACT:** The communication will consist of data transfer in which we are using GSM module for making it as wireless communications is used in this project for making better and longer distance communication. In this project we are using ATmega8 embedded microcontroller for implementing this technique in home or industries. The appliances like fridge, bulb, fan, television etc. are connected to the microcontroller through the relay. we can switch ON and OFF the appliances by using switches whenever we need. the power consumed by the appliances is measured. the consumption of power by the appliances is measured by the sensing unit. The power used is calculated with the help of current transformer. The current transformer, which gives the current consumed by the appliances and then the current, is converted into voltage by the current to voltage convert. the step down transformer will help the voltage to convert into 5V. the consumption of power is finding out by the program loaded in embedded controller .in order to save the power we are proposing two types of wiring i.e. normal wiring and restricted wiring. Under normal mode we can use maximum power and under restricted mode the restricted power is activated in order to manage the power across the area .under restricted period we can use only limited house appliances when the usage of power is beyond the limited power automatically the buzzer will give an alarm to alert the consumers in order to switch off the unused appliances within a limited period of time. if the consumer fails to switch off the unused appliances within a period, automatically the power will shut down in the consumer house.

**Keywords:** Energy Management Using GSM

## I. INTRODUCTION

The wireless communication is increasing day by day. This has motivated us to use mobile phones to remotely control household appliances and to receive a feedback SMS about the security and safety of the house. In this report we describe a remote appliance control system which can control different household appliances by sending a SMS from a mobile phone and monitor the safety and security of the house just by a SMS. This controller is extremely handy at places where we have to control the ON and OFF switching of the devices as no wired connection is required between the switch and the home appliances as it can be controlled from any place in this world. The microcontroller would then control the home appliances based on the information given to it and send a feedback during a security breach and it also send a feedback during gas leakage or if a fire takes place. The proposed solution is easy to use, simple, secure, and robust and can also be controlled through android mobile phones through and android application.

## II. METHODOLOGY

### A. Block diagram

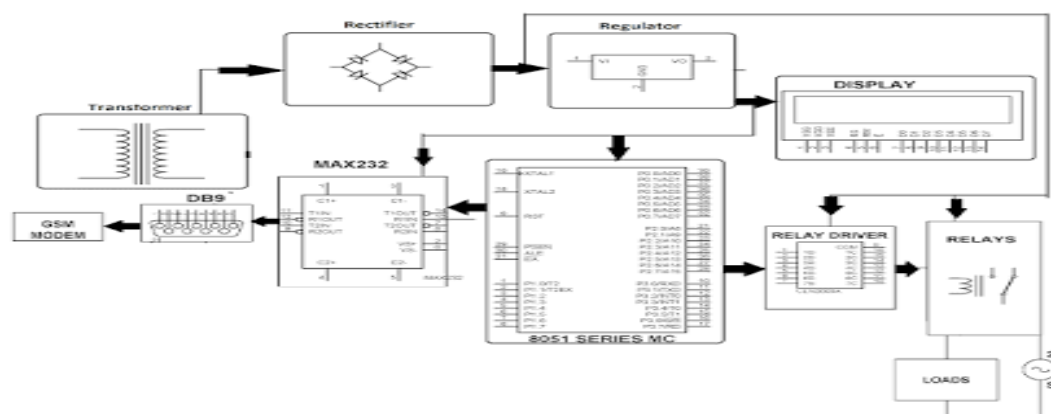

Figure 1. Block diagram

The main objective of this project is to develop a device that controls the home appliances through SMS with integrated acknowledgement feature. Unlike the conventional system present in houses, where one has to manually switch on and off the appliances. The proposed system allows the owner of the house to control the appliances by just sending an SMS to the device and then also receiving the status of the same via return SMS. A concept of wireless communication

### B. Circuit diagram

In this paper we describe a simple remote home appliance control, security and safety system using GSM SMS (Short Messaging Service). The system has two parts, namely; hardware and software. The hardware architecture consists of a stand-alone embedded system that is based on 8-bit microcontroller (ATmega8), a GSM handset with GSM Modem (SIM900), relay module, The software part consists of

programming in arduino and an android based application run on android phone. The GSM modem provides the communication media between the home owner and the system by means of SMS

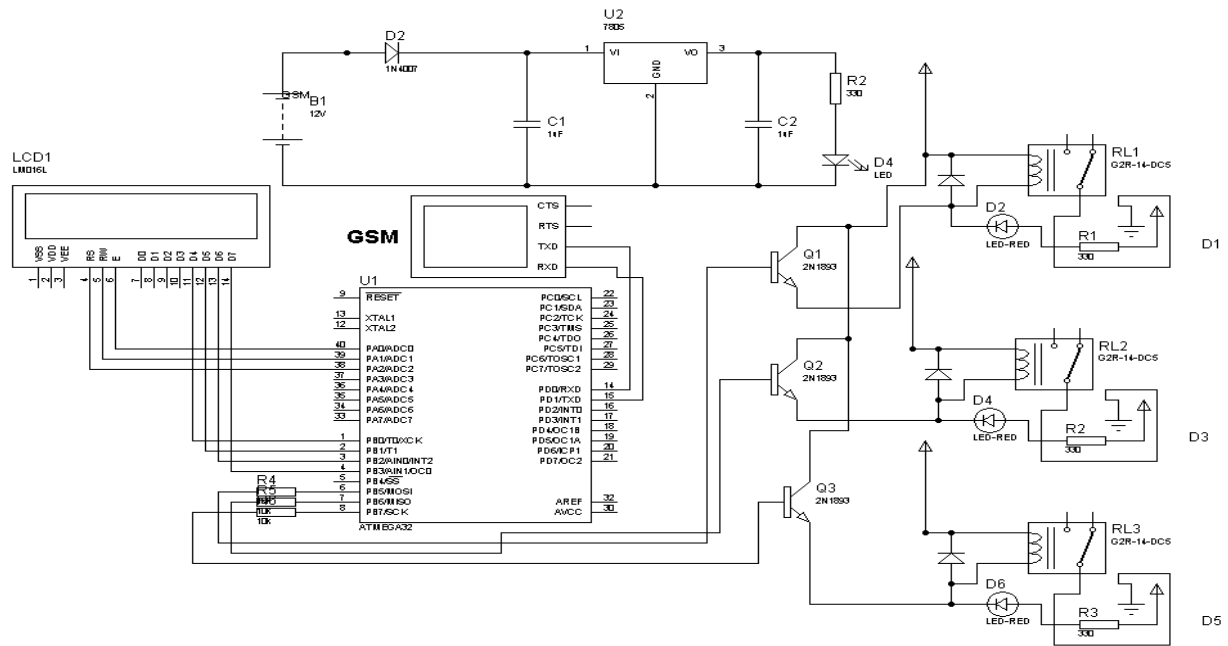

Figure 2 circuit diagram

The SMS consists of commands to be executed. The format of the message is predefined. The SMS message is sent to the GSM modem via the GSM public networks as a text message with a definite predefined format. Once the GSM modem receives the message, the commands sent will be extracted and executed by the microcontroller. The system will interpret the commands and turn the appliances ON/OFF accordingly via the switching module. For the home security and safety system, in case of security breach, fire and gas leakage microcontroller will ring the alarm and send a feedback message through the GSM modem to the GSM handset

### Components

Microcontroller, LED, Relay, Resistor, Capacitor, Voltage regulator, Display GSM modem, diode

### III. CONCLUSIONS

After study the literature work of project we are able to understand the working function of each part of project also we collect the information of all components. We had designed circuits of our project and connected various circuits. The project is a one part of industries and we have study the process of industries so we are able to how implementation of project is possible in industries.

### ACKNOWLEDGMENT

With a deep sense of gratitude and respect, we would like to extend my sincere thanks to Internal Guide and External Guide. For their kind attention and guidance which have made the Project successful. It is a matter of proud to study under such an experienced and expert faculty to understand and address current problem. Apart from technical skill we also learned the quality of 'accuracy in documentation' external guide & internal guide have also given us current project topics for seminar preparation which helped me in better preparation of presentation during Project review. We would like to express Our heartfelt gratitude to Prof. M.M. Desai (H.O.D, Electrical department) to provide us full support in utilizing the lab resources to perform our dissertation work.

### REFERENCES

- [1] Sedra and Smith, Microelectronic Circuits, fourth edition, Oxford University Press, 1998
- [2] International Journal of Advanced Research in Computer and Communication Engineering Vol. 4, Issue 1, January 2015.
- [3] Alkar, A. Z., & Buhur, U. (2005). An Internet Based Wireless Home Automation System for Multifunctional Device IEEE Consumer electronics, 51(4), 1169-1174. Retrieved from [http://www.thaieei.com/embedded/pdf/Automation/2002\\_2.pdf](http://www.thaieei.com/embedded/pdf/Automation/2002_2.pdf)
- [4] Uhuegbu, C.C., and Ayara W.A., "Delay Timer (Relay driver) for home electrical appliances", Archives of Physics Research, 2011, ISSN : 0976-0970
- [5] Zulkifli Othman, Rohaida Husin, Mohd Faisal Saari, "Automatic Street Lighting System for Energy Efficiency Based on Low Cost microcontroller", ISSN: 1473-804, January 2005
- [6] Hari Charan Tadimeti, Manas Pulipati, "Overview of Automation Systems and Home Appliances Control using PC and Microcontroller", Volume 2 Issue 4, April 2013
- [7] Sajidullah S.Khan, Anuja Khoduskar, Dr. N.A.Koli, "Home automation system", IJAET/Vol.II/April-June, 2011/129-132
- [8] Stevens, Tim, "The smart office", ISBN 0965708101(1994)

# INTERNATIONAL JOURNAL OF NOVEL RESEARCH AND DEVELOPMENT

International Peer Reviewed & Refereed Journals, Open Access Journal

ISSN: 2456-4184 | Impact factor: 8.76 | ESTD Year: 2016

Scholarly open access journals, Peer-reviewed, and Refereed Journals, Impact factor 8.76 (Calculate by google scholar and Semantic Scholar | AI-Powered Research Tool), Multidisciplinary, Monthly, Indexing in all major database & Metadata, Citation Generator, Digital Object Identifier(DOI)

Impact Factor : 8.76 (calculated by google scholar)	Monthly, Multidisciplinary and Multilanguage (Regional language supported)
International Journal	Peer Review Journal Refereed Journal
Journal Soft copy, Research Paper, Certificate, DOi and Hard copy of Journal Provided.	Indexing In Google Scholar, SSRN, ResearcherID-Publons, Semantic Scholar   AI-Powered Research Tool, Microsoft Academic, Academia.edu, arXiv.org, Research Gate, CiteSeerX, ResearcherID Thomson Reuters, Mendeley : reference manager, DocStoc, ISSUU, Scribd, and many more
Automated Metadata Citation Generator	Fast Process and Low Publication Charge
Provide the Mail and SMS notification	Approved, Open Access Journal
Highly Secure SSL Website	Managed By IJPUBLICATION

Submit Your Manuscript/Papers To  
[editor@ijnrd.org](mailto:editor@ijnrd.org) | [www.ijnrd.org](http://www.ijnrd.org)

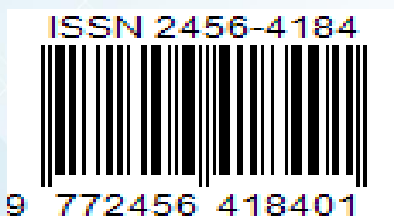

[www.ijnrd.org](http://www.ijnrd.org)

INTERNATIONAL JOURNAL OF NOVEL RESEARCH AND DEVELOPMENT  
ISSN NO: 2456-4184 | ESTD YEAR: 2016  
**IJNRD**  
IMPACT FACTOR: 8.76 BY GOOGLE SCHOLAR

Scholarly open access journals, Peer-reviewed, and Refereed Journals, Impact factor 8.76 (Calculate by google scholar and Semantic Scholar | AI-Powered Research Tool) , Multidisciplinary, Monthly, Indexing in all major database & Metadata, Citation Generator, Digital Object Identifier(DOI)

**CALL FOR PAPER**  
Paper Submission Till: 29<sup>th</sup> of Current Month  
Submit Your Paper online @ [www.ijnrd.org](http://www.ijnrd.org)

Benefits of Publishing Paper in IJNRD  
- Quick and Speedy Review and Publication Process  
- A digital object identifier (DOI) and Hard-soft Copy of Certificate  
- Email and SMS Support to Author  
- Fully Automated Process and Received Notification  
- Digital Storage (SS) Based website and Author Search  
- Periodical Reviews from Well-known Institutions / Universities across the world  
- Provide author research guidelines & support by email, SMS and the call  
- Indexing of paper in all major online journal databases like Google Scholar, Thomson Reuters, Mendeley, Academic.edu, arXiv.org, Research Gate, CiteSeerX, DOI, DRJI, DocStoc, GetCited, Scopus, WJCI, WJDF, Index Copernicus Open J Gate, ISSUU, Scribd

EDITOR@IJNRD.ORG  
MO : 9429458311  
WWW.IJNRD.ORG

Contact us For bulk paper Publications and Conference @ [editor@ijnrd.org](mailto:editor@ijnrd.org)

Major indexing  
ISSN, Google, ResearchGate, Scopus, CiteSeerX, SSRN, WJCI, WJDF, Index Copernicus Open J Gate, ISSUU, Scribd